

Learn Conceptual Modelling to innovate, design and engineer Digital Ecosystems!



universität
wien

MEETING
DESTINATION
VIENNA

NOW • TOGETHER

OMLAB®

www.omilab.org

A Nonprofit Organization

PROGRAMME

NEMO2023

SUMMER

SCHOOL

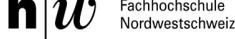

General Information

Summer School Venue

OMiLAB @University of Vienna
Faculty of Computer Science
Währinger Straße 29
1090 Vienna, Austria
T +43 1 4277-78943

Public means of transport

Tram: 5, 33, 37, 38, 40, 41, 42
Tram station:
Spitalgasse/Währinger Straße
Trip planning:
<http://www.wienerlinien.at>

NEMO2023 Team



Contact

Iulia Vaidian
T +43 660 7064283
E events@omilab.org

Taxi

Taxi 31300: +43 1 31300
Taxi 40100: +43 1 40100

Emergency calls

Rescue 144
Police 133
Fire department 122

Organization Team

Contact: nemo2023@omilab.org



Ayda Uzel



Mira Tjoa



Hannah Staffel

Technical Team

Contact: nemo2023@omilab.org



Danial Mohammadi Amlashi



Karlheinz Wachauer



Franz Staffel

Table of Contents

Welcome!	5
OMiLAB NPO	6
RG Knowledge Engineering and OMiLAB@UNIVIE	8
Social Events	9
Hotel contacts and NEMO Venue	10
NEMO Location: Vienna	11
Lecture Hall and PC Labs	12
Lecture Descriptions	13
Schedule Overview	32
ADOxx Practice Sessions	60
Digital Leaders Sessions	64
Innovation Scenarios	65

Main Sponsors



MEETING
DESTINATION
VIENNA
NOW ♦ TOGETHER



Research & University Partners

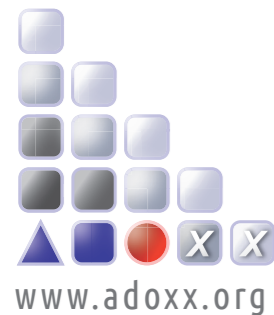

Organizer



Welcome!

The NEMO Summer School Series welcomes you to its 9th Edition, hosted by the University of Vienna!

As in the previous editions, this year's summer school will bring together a wide international community of academics and students with interests in various aspects of conceptual modelling. Since in today's enterprises modelling methods are widely used for numerous purposes. NEMO2023 will focus on the design and implementation of Enterprise Digital Twins and Ecosystems addressing different domains and approaches of modelling:

- Foundations of Conceptual Modelling, e.g. formal methods and tools for the creation, transformation, and application of modelling methods.
- Semantics and Technologies for Digital Ecosystems, e.g. meta-modelling platforms, model-value functionality, interaction with diverse smart devices and multi-client applications.
- Enterprise Digital Twins, e.g. Enterprise Information Systems, security frameworks, and lifecycle behaviour.
- Cross-cutting Issues, e.g. information privacy, risk management and governance, and quality assurance of models and methods.

Participating students have the opportunity to acquire knowledge by listening to more than 40 speakers from all over the world, covering current topical developments. And in order to consolidate it, practical sessions will take place. There, students will develop prototyping solutions to different kinds of problems and will discuss issues encountered in enterprises and practice. But to form a community, common experiences to bond are needed as well. Different cultural activities and social events will assure the start of a closely linked international community of young specialists.

We would like to thank all the speakers and their teams, who supported us with their commitment and work along the way in order to create this event.

The summer school could not have been realized without the work of the organizational team at the OMiLAB@UNIVIE and the support of the Faculty of Computer Science at the University of Vienna.

We hope that you all will have an extraordinary time, learning and enjoying your time at the NEMO Summer School!

Dimitris Karagiannis

Heinrich C. Mayr



Vision: we support an active global community for conceptual modelling that benefits from open artefacts.

Community of Practice: supported by a non-profit organisation (NPO) headquartered in Berlin, Germany and governed by a Scientific Advisory Board (SAB).

Digital Innovation Environment (DiEn): dedicated research and experimentation space for modelling method engineering equipped with tools to explore method creation and design, experiment with method engineering and deploy open-source software tools and services for modelling. OMiLAB acts as facilitator to the development and application of methods to communities who value models.

Network of Nodes: each node focuses on their own core topic and expertise supported by the collaborative, innovative and explorative space driven by DiEn. Individual engineers, researchers and different stakeholders can work together and contribute to modelling method creation, implementation and model-driven value creation.

Openness: to all those interested, either as individuals or as institutions. It acts as a platform where participants can bring in ideas related to modelling and engage in the exploration process. OMiLAB follows a user-driven approach in its understanding of the term "model" thus users are not limited to a certain domain or functional area of organisations. There are useful models in widely different domains like information technology, medicine as well as various models for functional areas like procurement, marketing, logistics and engineering.

the AMME Lifecycle

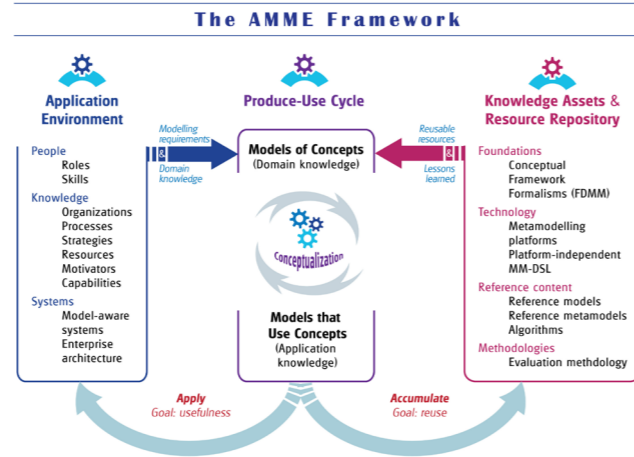
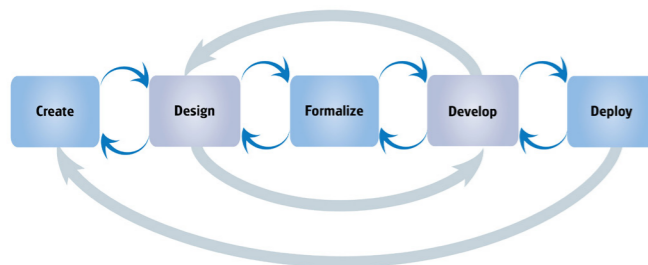

OMiLAB Community of Practice Benefits:

- knowledge-transfer between scientists, educators and innovators,
- access to infrastructure and open-source services,
- collaborative network of members that are active in domain-specific issues,
- amplification instruments which leverage the impact of the activities performed,
- conferences, workshops, seminars,
- common projects,
- research and teaching stays, internships and traineeships, and
- publications.

Digital Innovation Environment Resources:

- **Knowledge and procedures:** the Agile Modelling Method Engineering Framework (AMME), the Conceptualization Lifecycle, trainings, methodologies.
- **Technology:** open source platforms (e.g. ADOxx, OLIVE) and open source software tools (e.g. Bee-Up, Scene2Model).
- **Community of Practice:** events, publications, exploitation opportunities in third-party funded projects, the NEMO Summer School Series, the ADOxx Crash Courses, Digital Design Thinking Workshops and Bee-Up Tutorials.

Contact

OMiLAB NPO

Lützowufer 1
D-10785 Berlin

T: +49 30 2636 7863

E: info@omilab.org



We are global ...

<https://www.omilab.org/nodes>

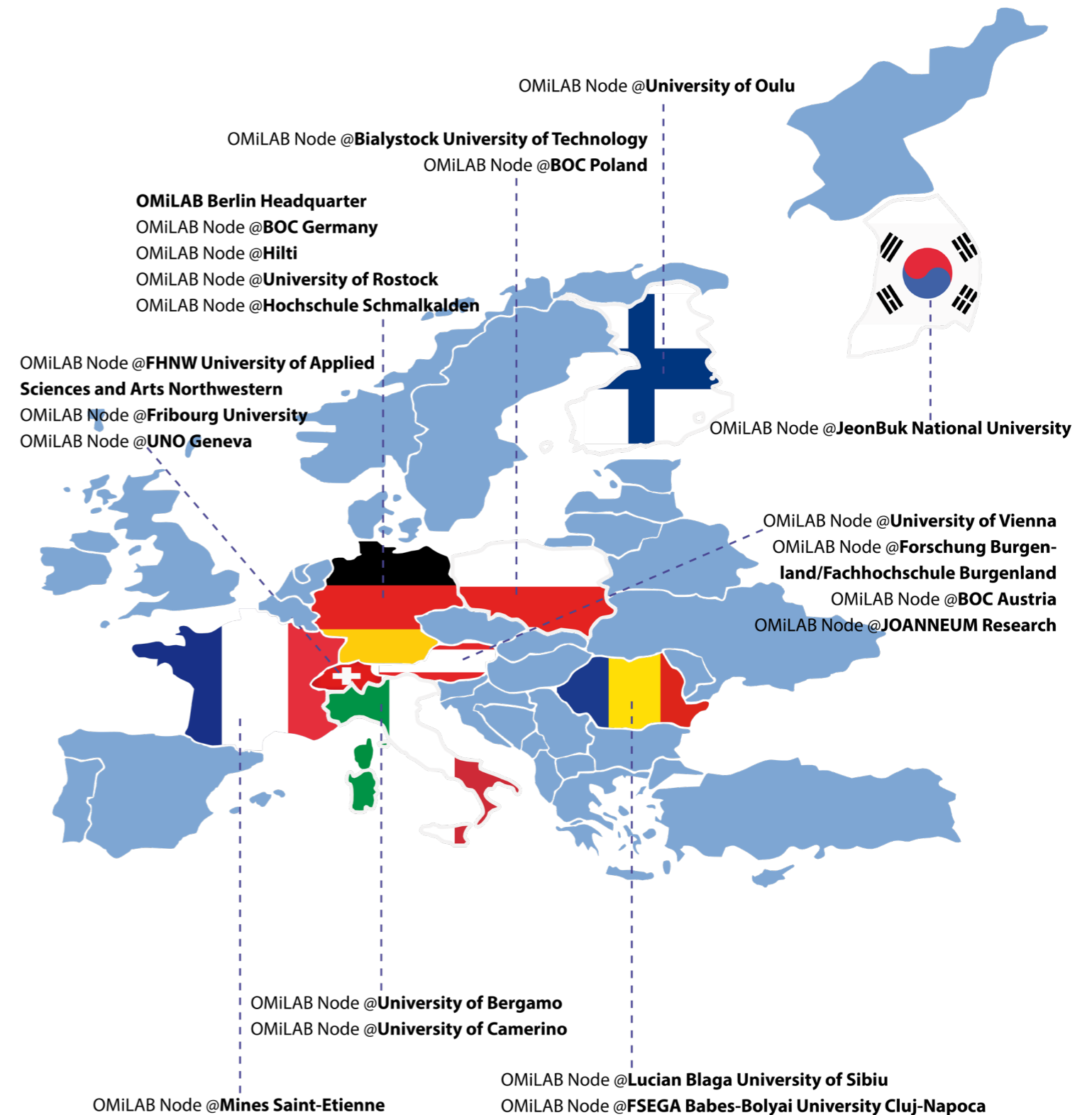

20 OMiLAB Nodes



9 Countries



2 Continents

Research Group Knowledge Engineering and the OMiLAB Vienna Node at University of Vienna

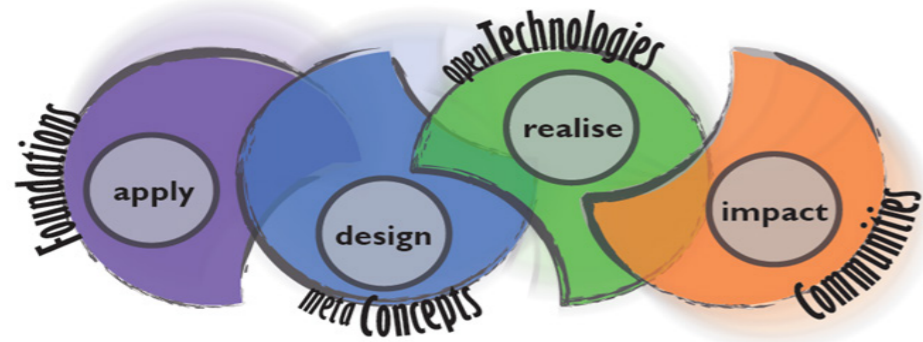

To provide transparent, ubiquitous knowledge that can be semantically processed by IT systems is the main research goal of the Research Group Knowledge Engineering. The group develops concepts for modelling languages and methods as well as step models and realizes concrete models. The contributions herewith advert to the research paradigm of design science in business informatics. Thereby realized results are deployed primarily within the research field of modelling methods and find their applicability in the form of information systems in the economy.

According to the development plan of the University of Vienna and the Faculty of Computer Science the scientific work of the research group is associated to the overall defined research focus "Knowledge-based Methods and Technologies for Digitalisation". Within this core area the work accomplished by the group provides novel research results in the areas of Meta-Modelling, Semantic Technologies, Hybrid Method Engineering and Intelligent and Agile Agents.

Based on mathematical and statistical foundations, theoretical approaches are adapted and applied. The fundamental research paradigm relies on concepts of meta-modelling that are further developed and deployed to derive knowledge out of (un)structured data on the one side and to provide transparent knowledge with formal and semi-formal modelling methods on the other side. The developed meta-models are realized with open

technologies in form of web based user and context specific applications and made available to the community.



In order to promote the exchange in regards to content and technological advancements in the method engineering community, the group has established the OMiLAB (Open Model Laboratory).

OMiLAB@UNIVIE is equipped with tools to explore method creation and design, experiment with method engineering and deploy software tools for modelling. The dissemination of established know-how, the exploitation of recent research results and their further development assure a sustainable impact on the community.

The Agile Modelling Method Engineering Framework is one of the core knowledge resources provided by the OMiLAB@UNIVIE. Design Thinking is another valuable expertise of the node, enhanced by the development of the Scene2Model tool.

Contact

Prof. Dr. Dimitris Karagiannis

OMiLAB@UNIVIE

Research Group Knowledge Engineering
Währinger Straße 29, 1090 Vienna, Austria

T: +43 1 4277 78901

E: dk@dke.univie.ac.at

SOCIAL Events



The NEMO Summer School comes with a programme full of lectures and working group sessions: the participants, students and lecturers thus will experience two intensive weeks of insights into the current state of research, theory and practice of modelling.

However, this is only one side of the coin: the other side is the opportunity to meet student colleagues and renowned professors from all over the world, to discuss with them, to exchange ideas, to learn from each other, and to make new friends - all that in the beautiful and exciting capital of Austria, Vienna.



A special „Get Together“ evening is planned for the first day. We invite you to enjoy some drinks and BBQ food. This event will allow participants to get to know each other right from the start of the summer school to facilitate cooperation during the practical sessions and in the preparation of the student presentations from the last day.

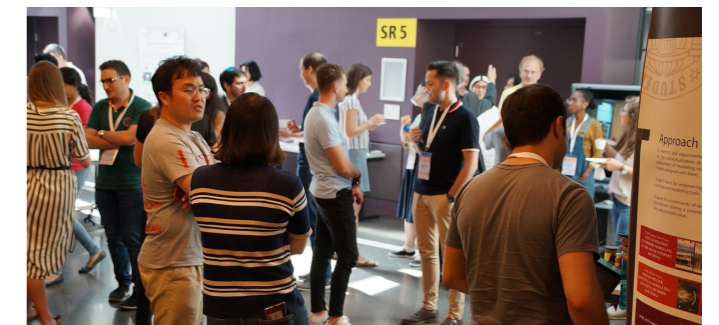

HOTEL CONTACTS & NEMO VENUE



Hotel Geblergasse***

Geblergasse 21, 1170 Vienna
Tel.: +43 (1) 4063366

Hotel Atlanta****

Währinger Straße 33, 1090 Vienna
Tel.: +43 (1) 4051230

NEMO VENUE

Währinger Straße 29, 1090 Vienna
Tel.: +43 (1) 4277 78943

Vienna



VIENNA - CITY OF DREAMS
HOME OF SIGMUND FREUD - HOME OF PSYCHOANALYSIS

POPULATION 2.6 million



= about 1/3 of all Austria



- capital City of Austria
- largest city in Austria
- most visited of Austria



DANCING is a tradition! over 400 balls each year



50% Green Space in Vienna



120 M OF GREEN SPACE PER 1 Viennese

- world's oldest ZOO
- Europe's oldest FERRIS WHEEL
- world's longest residential BUILDING (< 1 km in length)



- 651 years of teaching
- founded by Duke Rudolph IV in 1365
- the OLDEST UNIVERSITY in the German-speaking world



VIENNA - CITY OF MUSIC HOME TO MOZART, BEETHOVEN, SCHUBERT & J. STRAUSS



9 NOBEL PRIZE WINNERS
15 FACULTIES

Lecture Hall and PC Labs



Address:

Faculty of Computer Science
Währinger Straße 29
1090 Vienna

Basement (UG1):

Lectures in HS 1
Coffee Break in the Basement Lobby

1st Floor & 2nd Floor (1.0G - 2.0G):

Practice Sessions in:
PC2, PC3, PC5 & PC6

Ground Floor (EG):

Registration

4th Floor (4.0G):

Organisation Team
OMiLAB@UNIVIE

LECTURE

DESCRIPTIONS

Overview

Lectures

Boucher: The Industrial Transition towards Smart Product-service-Systems: Enterprise Modelling to Support Value Creation Processes	38
Buchmann: KG4SDSE: Knowledge Graphs for Semantics-driven Systems Engineering	40
Coyne: Practical Aspects of Implementing Digitalization	16
de Kinderen: Value Modeling for Ecosystem Design: An e3value Primer, Application Scenarios, and Lessons Learned	34
Döller: Tracing the Essence of Metamodeling	19
Eder: Modelling Temporal Requirements of Processes	26
Fafalios; Marketakis: Holistic Data Management and Semantic Interoperability in Historical Research: From Data Modeling and Integration to Data Exploration and Analysis	29
Fill: Enterprise Modeling and Blockchains: Recent Findings and Future Prospects	45
Florez: Embracing Imperfection in Enterprise Models	54
Frank: Multi-Level Modeling with the FMMLx: Integrated Design and Execution of Domain-specific Modeling Languages and Models	22
Ghiran: Explore Knowledge Graphs for Systems Engineering	41
Glinz: The Role of Requirements in the Digital Age: Requirements Engineering Revisited	21
Gordijn: How to Model Fair Ecosystems?	48
Hara: Japanese Creative Service as a Next Generation Enterprise Modelling	23
Helfert; Alfano: Health and Wellbeing Ecosystem of the Future: Person-Empowerment, Compliance and Governance	27
Hinkelmann: Ontology-based Enterprise Modelling for Human and Machine Interpretation	31
Johannsen: Towards Modeling-based Process-oriented Quality Management (PQM) for Environmental Sustainability	36
Karagiannis: How Metamodeling Supports Digitalization	20
Kavakli: Capability Oriented Requirements Engineering	52
Kirikova: Enterprise Modeling as a Knowledge Source in Systems Engineering	42
Lee: Process Algebra to Model Probabilistic Behavior of Smart IoT	30
Loucopoulos: PhD Research and Beyond within EIS: Trials and Tribulation	55
Lukovic: Organizational Capability for Information Management – Do We Feel a Big Data Crisis?	35
Mayr: Conceptual Models: Instruments for Digital Ecosystem Development	17
Medini: Improving Agility in the Post-mass Customization Era	44
Moser: Improving Communication between IT and Business	50
Nemetz: Challenging the Design of Digital Products and Services with Modelling Approaches	37

Overview

Lectures (continued)

Oberweis: Business Processes as Driver for Digital Transformation within Business Communities	49
Pankowska: No-coding Approach for Business Logic Modelling	25
Pastor: From Requirements to Code: Conceptual Model-based Software Design	18
Pezzotta: Service Engineering Models for the Design and Development of Digitalised Product-service Systems	39
Proper: Understanding Enterprise Modelling Practices	47
Rodrigues da Silva: The ITLingo RSL Language and Its Support by the ITLingo-Cloud Platform	43
Rossi: Data Asset Monetization as a Modeling Concern	46
Sandkuhl: Business Innovation with AI – Potential, Cases and Methods	24
Vanthenien: Integrating and Explaining Decision Models	28
Vössner: Pre-Conceptual Modeling for Exploring Actors and Interactions in Real World Systems	51
Züllighoven: Managing Ship Arrivals in a Port: The Design Process of Interactive Application Software Using Metaphors and User Participation	53

OMiLAB Day

OMILAB NPO: An Introduction	56
The Transformation of Hilti's Software Support to Customer Advocates	57
The Open-Source Software: Scene2Model and CM Tools	58
The Community of Practice: Focus on Skills and Cases	59

ADOxx Practice Sessions

ADOxx Best Practice: Develop and Use Conceptual Models with Bee-Up	60
Digitalization in Smart Cities with ADOxx	61
The Open Source Metamodeling Platform	62

Digital Leaders

Innovate Business Models	64
Engineer IoT Environments	64
Realize CPS Applications	64

Innovation Scenarios

Innovation Scenarios Using Digital Design Thinking	66
--	----

PRACTICAL ASPECTS OF IMPLEMENTING DIGITALIZATION

John Martin Coyne, IAEA - International Atomic Energy Agency

CONCEPTUAL MODELS: INSTRUMENTS FOR DIGITAL ECOSYSTEM DEVELOPMENT

Em. o. Univ.-Prof. Dr. Dr.H.C. Heinrich C. Mayr, Alpen-Adria-Universität Klagenfurt, Austria

ABSTRACT

The Safeguards Department of the International Atomic Energy Agency (IAEA) ensures the peaceful use of nuclear material and activities in accordance with legal agreements between the IAEA and member states. In order to verify compliance with the agreements, Safeguards staff verify the consistency between member states declarations with observations in the field (often at nuclear facilities) along with observations from other Safeguards relevant information collected in headquarters. The Department has developed and continues to develop a suite of custom designed software to enable the department's work. The digitalization of work processes is key to increase the efficiency and effectiveness of the workforce. Some important considerations in this regard are: It is vital to know your users, the business of your users, and your user's capabilities. Knowledge gaps in any of these areas increases risks, and increases the likelihood of project failure. Well designed digital workflows can bring a range of benefits which may not be immediately evident. While digitizing a workflow can help stakeholders understand what needs to be done now, over time the output could be used to identify patterns of past behavior, and can form the basis of future predictions. Analog processes may allow for free text input, which may contain inconsistencies which lead to impediments for evaluating the process. It is beneficial to digitize the whole process as early in the lifecycle as possible, which may require changing stakeholders' existing processes.



John Martin COYNE, United States of America, has been appointed as Director, Office of Information and Communication Systems, Department of Safeguards, as of 1 July 2018. Prior to Mr Coyne's appointment, he was Acting Director, Office of Information and Communication Systems, Department of Safeguards, since 1 February 2015. Since joining the Department of Safeguards in 2012, Mr Coyne has served as Section Head, Section OC4, Division of Operations C and Section Head, Coordination and Support Section, Division of Operations C, Department of Safeguards. Before joining the Agency, Mr Coyne held several positions in CTBTO (Programme and Project Coordinator, Section Chief, Unit Head and Software Engineer) and in Science Applications International Corporation in Arlington, VA, United States. Mr Coyne has a Master's Degree in Geophysics from Cornell University and a Bachelor's Degree in Geological Sciences from the Pennsylvania State University.



Contact:

John Martin Coyne
J.COYNE@iaea.org



Heinrich C. Mayr has been Full Professor of Informatics at the Universität Klagenfurt since 1990. Until then he was assistant professor at the Universität Karlsruhe (today: KIT), visiting professor at several universities and managing director of a German software company. His research is documented in more than 250 publications and includes methods of information system design, domain specific modeling languages, requirements modeling as well as knowledge management. Among other things, he held the position of President of the Gesellschaft für Informatik (GI) and Vice-President of the Council of European Professional Informatics Societies (CEPIS). He was rector of his university for 6 years. For 20 years he was editor-in-chief of the „Lecture Notes in Informatics“ and chairman of the council of the Software Internet Cluster SIC. Currently, he is a board member of the „Kärntner Beteiligungsverwaltung.“



Contact:

Em. Prof. Dr. Heinrich C. Mayr
Heinrich.Mayr@aau.at

ABSTRACT

Dealing with modeling, i.e., defining modeling languages and using them consistently is not everyone's cup of tea. While in engineering, especially for life-critical systems, modeling is a matter of course, in the practice of the software business one often encounters the opinion that the effort for systematic modeling does not pay off. Often also, the object under development is estimated so complex that it cannot be described with a modeling language but must be programmed right away. This is of course a contradiction in terms. For, programs are (representations of) models of processes, that are to be executed by a computer. In short: programming is modeling! Accordingly, requirements engineering also consists to a large extent of modeling. For practitioners, it would be desirable to be able to use requirements models as building templates, i.e., prescriptive models (specifications) that evolve in parallel with the system and become descriptive models of the final product. It is the task of Informatics to provide suitable methods for this! Consequently, Informatics has for long systematized the field of modeling, for example by introducing model hierarchies, by ontological foundations, by developing universal modeling languages such as UML, or by specifying domain-specific modeling methods (DSSMs) for areas of application where universal approaches fail. For the design and implementation of reliable and resilient Enterprise Digital Twins and Digital Ecosystems, Conceptual Modeling is the key method. In this talk we aim at a better understanding of what this method is about. We will address the „anatomy“ of conceptual models and show how they can be characterized by a signature. We combine this with a transparent explanation of the nature of conceptual models as the link between the dimension of language representation and the dimension of fixing a unique model semantics: Figuratively this leads to the triptych of conceptual modeling. Building on this, we show how digital ecosystems can be designed and developed in a rigorous model-centered approach. This is illustrated by the results of projects we have carried out in the areas of assistance systems and the development of mechatronic systems.

FROM REQUIREMENTS TO CODE: CONCEPTUAL MODEL-BASED SOFTWARE DESIGN

Prof. Dr. Oscar Pastor, Universidad Politecnica de Valencia, Spain

ABSTRACT

A crucial success factor in information systems development is the alignment of the final software product with business goals, business semantics and business processes. Developers should be freed from programming concerns and be able to concentrate on these alignment problems. To assess that the right capabilities are used, sound Conceptual Modeling (CM) techniques within a Model-driven system development (MDD) must be applied in order to provide a structured and systematic approach to systems development, where developers can successfully use model transformation technologies to derive models of a lower abstraction level that can be further refined, even generating software code automatically. From the experience got with the use of advanced MDD platforms, this keynote will show how to use a Capability-driven Development (CDD) strategy in order to integrate business process modelling (BPM), requirements engineering (RE) and object-oriented conceptual modelling with the objective of leveraging MDD capabilities. The current state of the art on modelling methods and code generation tools will be discussed to explore different ways to match an information system with business requirements. Concrete principles, concepts and common practices of MDD will be presented with a special focus on model-driven requirements engineering, meaning by it how BPM and requirements models can be embedded in a complete CM-based software production process.

Oscar Pastor is Full Professor and Director of the “Centro de Investigación en Métodos de Producción de Software (PROS)” at the Universidad Politécnica de Valencia (Spain). He received his Ph.D. in 1992. He was a researcher at HP Labs, Bristol, UK. Supervisor of 20 completed PhD theses and 31 completed Masters theses on topics that relate to Conceptual Modeling. His research activities focus on conceptual modeling, web engineering, requirements engineering, information systems, and model-based software production. He created the object-oriented, formal specification language OASIS and the corresponding software production method OO-METHOD. He led the research and development underlying CARE Technologies that has created an advanced MDA-based Conceptual Model Compiler called Integranova, a tool that produces a final software product starting from a conceptual schema that represents system requirements. He is currently leading a multidisciplinary project linking Information Systems and Bioinformatics notions, oriented to designing and implementing tools for Conceptual Modeling-based interpretation of the Human Genome information.



Contact:

Prof. Dr. Oscar Pastor
opastor@dsic.upv.es

TRACING THE ESSENCE OF METAMODELLING

Mag. Victoria Döller, University of Vienna, Austria

ABSTRACT

Victoria Döller is a PhD student at the Research Group for Knowledge Engineering of the University of Vienna. With a masters degree in mathematics and a profound background in psychology she is strongly interested in artificial intelligence and cognitive modeling as well as in conceptual modeling and metamodeling, especially in examining and formalizing common requirements of metamodels. Prior to her PhD position she worked as a software developer in the insurance sector and gained experience in the non-academic application of Knowledge Engineering and Modeling.

Metamodeling concepts comprise not only the selection of appropriate methods but also the syntactic and semantic specification of modeling techniques. Moreover, these techniques need to be accompanied by a proper notation as well as mechanisms and algorithms that enable the processing of created models. Lastly, the actual way of applying a certain modeling technique by means of a modeling procedure needs to be specified.



Contact:

Mag. Victoria Döller
victoria.doeller@univie.ac.at

HOW METAMODELLING SUPPORTS DIGITALIZATION

Prof. Dr. Dimitris Karagiannis, University of Vienna, Austria

ABSTRACT

Internet's evolution into a generic platform and a pervasive environment enables the creation, provision and consumption of digital services. Cloud-based deployment models offer transparent access to services for a worldwide group of users. The models support 24/7 availability, location independence as well as autonomy of resource processing limitations. At the same time, digital services are the basis of new and innovative business models. All of the above is expected to take place in the digital transformation process. Is it really feasible this way?

Dimitris Karagiannis is head of the Research Group Knowledge Engineering at the University of Vienna. His main research interests include knowledge management, modelling methods and meta-modelling. Besides his engagement in national and EU-funded research projects Dimitris Karagiannis is the author of research papers and books on Knowledge Databases, Business Process Management, Workflow-Systems and Knowledge Management. He serves as expert in various international conferences and is on the editorial board of several international journals. He is member of IEEE and ACM and on the Special Interest Group on IT Governance of the Austrian Computer Society. He is the founder of the Open Models Laboratory, www.omilab.org.



Contact:

Prof. Dr. Dimitris Karagiannis
dk@dke.univie.ac.at

THE ROLE OF REQUIREMENTS IN THE DIGITAL AGE: REQUIREMENTS ENGINEERING REVISITED

Prof. Dr. Martin Glinz, University of Zurich, Switzerland

ABSTRACT

Martin Glinz is a full professor emeritus and head of the Requirements Engineering Research Group at the Department of Informatics, University of Zurich. He received a diploma in Mathematics and a Dr. rer. nat. in Computer Science, both from RWTH Aachen University, Germany, in 1977 and 1983, respectively. From 1983 to 1993, he was with BBC/ABB in Baden, Switzerland where he was active in research, development, training, and consulting in the field of software engineering. His research interests include requirements and software engineering, in particular modeling, validation, and quality -- and software engineering education. He was vice-dean of the Faculty of Business, Economics and Informatics and director of academic studies in Informatics from 2000-2006 and department head of the Department of Informatics from December 2007 to January 2016.

ABSTRACT

Requirements Engineering (RE) has been applied with remarkable success for specifying the requirements for systems or products. However, as RE has traditionally been performed as a heavy-weight, upfront process for creating a comprehensive specification, it has been criticized or even declared obsolete in recent years, particularly by the proponents of agile development. In this talk, I will shed light on the role of requirements in today's digital world, discuss how this relates to enterprise modeling, and show how modern RE can contribute to shaping, evolving and sustaining digital systems and products.



Contact:

Prof. Dr. Martin Glinz
glinz@ifi.uzh.ch

MULTI-LEVEL MODELING WITH THE FMMLX: INTEGRATED DESIGN AND EXECUTION OF DOMAIN-SPECIFIC MODELING LANGUAGES AND MODELS

Prof. Dr. Ulrich Frank, University of Duisburg-Essen, Germany

ABSTRACT

Conceptual models are of pivotal relevance for the design, maintenance and use of software systems. However, the design of modeling languages and corresponding tools suffers from serious limitations. They concern the lack of expressiveness, the lack of abstraction and, as a consequence, limited reuse and adaptability, as well as dissatisfactory integrity. Over the last twenty years research on multi-level modeling has produced various approaches to overcome these limitations. Different from traditional language architectures such as the MOF, multi-level architectures enable an arbitrary number of classification levels. This way, they allow for the specification of DSMLs with more general DSMLs and enable relaxing the notorious power-generality trade-off. Furthermore, frustrating problems caused by the lack of expressiveness MOF-like language architectures suffer from can be avoided. This talk will start with explaining the serious shortcomings of prevalent language architectures. Subsequently, essential features of multi-level language architectures are presented. Finally, the talk will give an introduction to a specific multi-level language, the FMMLx, and a corresponding language engineering, modeling and execution environment, the XModelerML. Among other things, the XModelerML enables the common representation of models and tools (because it features a multi-level programming languages). Thus, it does not only allow to overcome the notorious synchronization problem, but also to develop new architectures of enterprise application systems that provide for unprecedented levels of reuse, adaptability and user empowerment. The presentation of core concepts is supplemented with a short tool demo.

Ulrich Frank holds the chair of Information Systems and Enterprise Modelling at the Institute of Computer Science and Business Information Systems at the University of Duisburg-Essen. His main research topic is enterprise modelling, i.e. the development and evaluation of modelling languages, methods and corresponding tools. In recent years, he focused especially on multi-level modelling languages and corresponding tools. Further areas of research include method construction, (meta) programming languages, and advanced architectures of application systems. He is also interested in the philosophy of science and fundamental questions related to the subject of research in business information systems and computer science.



Contact:

Prof. Dr. Ulrich Frank
ulrich.frank@uni-due.de

JAPANESE CREATIVE SERVICE AS A NEXT GENERATION ENTERPRISE MODELLING

Prof. Dr. Yoshinori Hara, Kyoto University, Japan

ABSTRACT

Yoshinori Hara serves as professor, Graduate School of Management, Kyoto University. His current research focus includes innovation management, service and design management, and open innovation with IT frameworks. Prior to joining Kyoto University, he held various research and key management positions at R&D organizations in NEC Corporation, for 13 years in Japan, and for 10 years in the Silicon Valley, California, USA. He was responsible for conducting research and development on advanced ubiquitous computing including Web/Hypermedia systems, mobile & embedded systems, adaptive user interfaces, advanced information retrieval technologies, system security & reliable systems. From 1990 to 1991, he was a Visiting Researcher at the Department of Computer Science, Stanford University. He received his B.E. and M.E. from University of Tokyo, and his Ph.D. from Kyoto University.

We define Japanese creative services and discuss how they have been sustained successfully and its application to global service enhancement. There are many "Shinise" (shops of long standing) service companies in Japan that are quite unique compared to the companies located in any other geographical region. They typically have anecdotal values based on nature and seasons, various types of culture, histories, and/or lifestyles. Several Japanese creative services are expanding their activities toward global markets. We explain the mechanisms of the sustainability and scalability of advanced cases of Japanese Creative Services. A key aspect of the mechanism is a communication between service providers and consumers based on sharing/interpreting/utilizing of tacit context in a community. For analyzing the key aspect, we propose the combined approach of sociology/anthropology, psychology, engineering and design thinking. We developed a meta-modeling platform for handling the combined analysis of the Japanese Creative Services. We believe that this kind of approach will contribute to creating new values within the field of service science and for value-added global services.



Contact:

Prof. Dr. Yoshinori Hara
hara.yoshinori.2a@kyoto-u.ac.jp

BUSINESS INNOVATION WITH AI-POTENTIAL, CASES AND METHODS

Prof. Dr. Kurt Sandkuhl, University of Rostock, Germany

ABSTRACT

Al is on the way from a hype technology and omnipresent buzzword to a significant factor for innovation. The success stories of AI from larger enterprises and the technological possibilities of prominent AI applications, such as Deep L, OpenAI's ChatGPT, or IBM's Watson receive much attention in the public discussion. However, AI also offers innovation potential for small and medium-sized businesses. The lecture will examine the potential of AI for business model innovation, process innovation and product/service innovation, including examples also relevant for small and medium-sized business. Furthermore, selected methods supporting the introduction of AI-based innovation in organizations will be discussed.

Kurt Sandkuhl, born 1963 in Germany, is full Professor of "Business Information Systems" at University of Rostock (Germany) and has an adjunct position as Professor of "Information Engineering" at School of Engineering, Jönköping University. He received a diploma (Dipl.-Inform.) and a PhD (Dr.-Ing.) in computer science from the Berlin University of Technology in 1988 and 1994, respectively. Furthermore, he received the Swedish degree as "Docent" (postdoctoral lecturing qualification) from Linköping University, Institute of Technology, in 2005. Sandkuhl's current research interests include the fields of information logistics, enterprise modeling, ontology engineering, and model-based software engineering. He has published three books in the field of electronic publishing and more than 150 papers in information logistics, enterprise knowledge management, CSCW, information services, and software architectures.



Contact:

Prof. Dr. Kurt Sandkuhl
kurt.sandkuhl@uni-rostock.de

NO-CODING APPROACH FOR BUSINESS LOGIC MODELLING

Prof. Dr. Małgorzata Pańkowska, University of Economics in Katowice, Poland

ABSTRACT

Małgorzata Pańkowska is PhD, Full Professor of Social Science and Chair of the Department of Informatics at the University of Economics in Katowice, Poland. She received the qualification in econometrics and statistics from the University of Economics in Katowice, the Ph.D. and the Doctor Habilitatus degree from the University of Economics in Katowice. She was visiting professor at ISLA Braganca in Portugal, Trier University in Germany, ICHEC in Brussels, Belgium, VGTU in Vilnius, Lithuania, Istanbul University in Turkey, Ionian University in Corfu, Greece, Universidad de Ibagué, Ibagué-Tolima, Colombia, and Lapland University in Kemi-Tornio, Finland. She is Vice-President in the Board of Information System Audit and Control Association (ISACA) Katowice Chapter. Conference Programme Committee Member: BIR 2022-2022 Perspectives in Business Informatics Research, ICDEc 2022 International Conference on Digital Economy, ISD 2021-2022 Information Systems Development, FedCSIS 2021, PC member 2nd International Forum of Cyber Security, Privacy, and Trust 2022.

Literature survey permits for conclusion that business process modelling is realized with the use of various technologies, notations, and software tools. This lecture aims to present that differentiation is right and valuable, because process modelling is conducted for achievement of different effects. This lecture focuses on just one process, named Publishing Cycle. University Publisher is the main actor in this process. First, this process is modelled in ArchiMate language to discuss process context, i.e., business, software, and infrastructure context. Next, models in BPMN and CMMN permit for discussion manual and automated tasks. Finally, the logic of business is presented with no-coding application development tools. Beyond process, the business documents and forms are modelled with the no-coding tools. The main components of application developed with no-coding technology cover input-output forms and software functionalities captured as a process. During the lecture, the open source no-coding tools are analyzed and compared. At the end, benefits of no-coding approach is discussed, particularly as valuable in pre-implementation system analysis.



Contact:

Prof. Dr. Małgorzata Pańkowska
pank@ue.katowice.pl

MODELLING TEMPORAL REQUIREMENTS OF PROCESSES

Prof. Dr. Johann Eder, Alpen-Adria Universität Klagenfurt, Austria

ABSTRACT

Processes are ubiquitous for modeling dynamic phenomena in many areas like business, production, health care, robotics etc. Many of these applications require to adequately deal with temporal aspects: durations, deadlines, temporal constraints and goals. Nevertheless, temporal aspects are not yet prominently treated in requirements engineering or business process management. Models for representing requirements need to express temporal properties of the context resp. the environment, which have to be considered for designing systems. And they need to express temporal conditions, which have to be satisfied or which represent properties of goals that should be reached. Models, therefore, contain constructs for durations, temporal constraints like admissible time-span between events, and deadlines. Furthermore, these models need a notion of correctness and we discuss different notions like satisfiability and controllability. We also present techniques, which can be employed to check whether temporal requirements are conflicting and to derive temporal properties.

Johann Eder is full professor for Information and Communication Systems in the Department of Informatics-Systems of the Alpen-Adria Universität Klagenfurt, Austria. From 2005-2013 he served as Vice President of the Austrian Science Funds (FWF). He held positions at the Universities of Linz, Hamburg and Vienna and was visiting scholar at AT&T Shannon Labs, NJ. The research interests of Johann Eder are databases, information systems and data management for medical research. A particular focus of his work is the evolution of information systems and the modelling and management of temporal information and temporal constraints. Another focus is the application of Information technology for medical research from information systems for biobanking, information privacy to modelling of biological processes.



Contact:

Prof. Dr. Johann Eder
Johann.Eder@aau.at

HEALTH AND WELLBEING ECOSYSTEM OF THE FUTURE: PERSON-EMPOWERMENT, COMPLIANCE AND GOVERNANCE

Prof. Dr. Markus Helfert, Maynooth University, Ireland
Dr. Marco Alfano, Maynooth University, Ireland

ABSTRACT

Markus Helfert is Professor in Digital Service Innovation at Maynooth University, Innovation Value Institute (Ireland) and the Director of the Business Informatics Group at Maynooth University. He is a Principle Investigator at Lero – The Irish Software Research Centre and at the Adapt Research Centre. His research is centred on Digital Service Innovation, Smart Cities and IoT based Smart Environments and includes research areas such as Service Innovation, Intelligent Transportation Systems, Smart Services, Building Information Management, FinTech, Data Value, Enterprise Architecture, Technology Adoption, Analytics, Business Process Management. Prof. Markus Helfert has authored more than 200+ academic articles, journal and book contributions and has presented his work at international conferences.

Dr. Marco Alfano is a Senior Researcher at the Innovation Value Institute (IVI), Maynooth University, and leader of the IVI Digital Health research cluster. He is also affiliated with Lero, the SFI Research Centre for Software, working on responsible use of AI in health and well-being by facilitating person/patient empowerment and seamless communication within the healthcare system (<http://cohealth.ivu.ie/>). His research interests include Responsible AI, Digital Health Transformation, Patient Empowerment, Human-machine communication, Data analytics, Semantic Web, Smart cities, Cybersecurity, and Open Data/Big Data. He has authored more than fifty peer reviewed articles for journals, books, and conferences.



Contact:

Prof. Dr. Markus Helfert
Markus.Helfert@mu.ie



Contact:

Dr. Marco Alfano
marco.alfano@mu.ie

ABSTRACT

Growing evidence supports the effectiveness of a novel, integrated approach to health and wellbeing by recognizing the interconnectedness of physical, mental, social, and other aspects of an individual's life. Achieving balance across all these domains is crucial to promoting overall health and wellbeing. Embracing an integrated approach is also driven by the importance of empowering individuals to take charge of their health and wellbeing, make informed decisions, and effect positive changes that enhance their overall quality of life. While digital technologies provide tools and platforms that promote healthy behaviors, foster social connectivity, and support mental and emotional wellness, they often work in isolation, do not aim for people empowerment, are not tailored to user needs, and can be overly complex for non-native digital users. This presentation reports on the research presently carried out at the Innovation Value Institute, Maynooth University, on the use of digital technologies to empower individuals to manage their health and wellbeing. In particular, it presents the architecture, data governance aspects and main characteristics of a Digital Ecosystem for Empowerment on Integrated Health and Wellbeing. As a key driver of the transformation, data requires appropriate governance practices underpinned by architectures that allow safeguarded and trusted data sharing. By providing access to personalized health information, resources, and tools, the ecosystem, among others, creates increased independence, supports healthy behaviors, reduces feelings of loneliness and isolation, and improves mental health and emotional wellbeing, ultimately leading to a higher and sustainable quality of life and relieving the pressure from the present healthcare system.

INTEGRATING AND EXPLAINING DECISION MODELS

Prof. Dr. Jan Vanthienen, KU Leuven, Belgium

ABSTRACT

Modelling business processes is essential for business effectiveness and efficiency. But knowledge-intensive processes incorporate lots of decisions and decision knowledge, that should not be hidden in process flows, because hardcoding (decision) rules in processes leads to complex and inflexible process models. In analogy with the Business Process Modelling & Notation Standard (BPMN), a Decision Model & Notation standard (DMN) was developed, that allows to model decisions and processes separately. This session is about decision modelling, and about how decision models and process models should be combined into an integrated model of processes and decisions. It is also about how decision models can be made explainable using a generic chatbot interface.

Jan Vanthienen is full professor of information systems at KU Leuven (Belgium), Department of Decision Sciences and Information Management, where he is teaching and researching on business intelligence, analytics, business rules, processes & decisions. He has published numerous papers in reviewed international journals and conference proceedings. and received the Belgian Francqui Chair 2009 at FUNDP and an IBM Faculty Award in 2011. Jan is actively involved in the Decision Modeling & Notation standard (DMN) at OMG (Object Management Group). He is also member of the IEEE task force on process mining, co-author of the Business Process Mining Manifesto and member of Leuven.AI – KU Leuven Institute for Artificial Intelligence.



Contact:

Prof. Dr. Jan Vanthienen
jan.vanthienen@kuleuven.be

HOLISTIC DATA MANAGEMENT AND SEMANTIC INTEROPERABILITY IN HISTORICAL RESEARCH: FROM DATA MODELING AND INTEGRATION TO DATA EXPLORATION AND ANALYSIS

Dr. Pavlos Fafalios, FORTH-ICS, Greece
Yannis Marketakis, FORTH-ICS, Greece

ABSTRACT

Dr. Pavlos Fafalios is a postdoctoral researcher at the Information Systems Laboratory and the Centre of Cultural Informatics of FORTH-ICS, as well as a visiting lecturer at the Department of Management Science and Technology of the Hellenic Mediterranean University. He has received a Marie Curie Individual Fellowship for the project ReKnow (No 890861) and has worked as group leader in several European and national research projects (including the ERC projects SeaLiT and RICONTRANS). His research interests fall in the areas of Information Retrieval, Knowledge Representation, Knowledge Engineering, and Semantic Web, with a special interest on interdisciplinary research in these areas. The results of his research have been published in more than 60 refereed research articles.

Yannis Marketakis is a R&D Engineer at the Information Systems Laboratory of FORTH-ICS. His main research interests include information systems, digital preservation, knowledge representation and data integration using semantic web technologies and conceptual modeling. He has been involved in several European and national research projects (the most recent ones are BlueCloud-2026, BlueCloud, MINGEI, BlueBRIDGE, VRE4EIC, etc.) and has co-authored more than 45 scientific publications and one book (Cinderella's Stick – A fairytale for Digital Preservation). He has more than 10 years of experience in carrying out applied research in the field of Information and Communication Technologies. He is experienced with the design and implementation of software applications, tools and services for large-scale infrastructures.



Contact:

Dr. Pavlos Fafalios
fafalios@ics.forth.gr



Contact:

Yannis Marketakis
marketak@ics.forth.gr

ABSTRACT

The course will describe and demonstrate a workflow model and a set of tools for holistic data management in the historical sciences: from recording and documenting historical information from primary (archival) sources, to modeling and integrating the data using a standard ontology, in particular the ISO standard CIDOC CRM (ISO 21127:2014), as well as exploring and analyzing the integrated (linked) data both quantitatively and qualitatively. We will motivate the problem, provide implementation details, and present real applications using data and requirements from two large ERC projects in the fields of Maritime History (project SeaLiT) and Art History (project RICONTRANS).

PROCESS ALGEBRA TO MODEL PROBABILISTIC BEHAVIOR OF SMART IOT

Prof. Dr. Moonkun Lee, Chonbuk National University, South Korea

ABSTRACT

In general, process algebra can be the most suitable formal method to specify IoT systems due to the equivalent notion of processes as things. However there are some limitations to predict smart IoT systems with the properties of distribution, mobility and real-time. For example, Timed pi-Calculus has capability of specifying time property, but is lack of direct specifying both execution time of action and mobility of process at the same time. And d-Calculus has capability of specifying mobility of process itself, but is lack of specifying various time properties of both action and process, such as, ready time, timeout, execution time, deadline, as well as priority and repetition. In order to overcome the limitations, this lecture presents a process algebra, called, dTp-Calculus, extended from d-Calculus, by providing with capability of specifying probabilistic transitions with the set of time properties, as well as priority and repetition. Further the method is implemented as a tool, called SAVE, on the ADOxx meta-modeling platform. It can be considered one of the most practical and innovative approaches to model probabilistic behavior of smart IoT systems.

Moonkun Lee is professor in Division of Computer Science and Engineering in Chonbuk National University, Republic of Korea. Received Bachelor degree in Computer Science, Pennsylvania State University, USA; Master and Ph.D. degrees in Computer & Information Science, The University of Pennsylvania, USA. Worked at CCCC, USA, as Computer Scientist; Developed SRE (SW Re/reverseengineering Environment); Applied to modernization of legacy OS and SW of NSWC in US Navy to Ada. Main research interests are SW round-trip engineering, distributed real-time systems, formal methods, ontology, behaviour engineering, etc. Currently focusing on Smart City and Factory in order to implement CPS (Cyber-Physical Systems) with dTp-Calculus in SAVE on ADOXX and Web Server.



Contact:

Prof. Dr. Moonkun Lee
moonkun@jbnu.ac.kr

ONTOLOGY-BASED ENTERPRISE MODELLING FOR HUMAN AND MACHINE INTERPRETATION

Prof. Dr. Knut Hinkelmann, University of Applied Sciences and Arts Northwestern Switzerland FHNW, Switzerland

ABSTRACT

Knut Hinkelmann is Head of the Master of Science in Business Information Systems at the FHNW University of Applied Sciences and Arts Northwestern Switzerland. He also is visiting professor at the University of Camerino, Italy, and research associate at the University of Pretoria, South Africa. In 1988 he obtained a diploma in Computer Science and in 1995 a PhD from the University of Kaiserslautern. After the study he worked for the Research Institute for Applied Knowledge Processing (FAW). Then he was researcher and head of the Knowledge Management research group at the German Research Center for Artificial Intelligence (DFKI). After having worked as product manager for Insiders Information Management GmbH, he joined FHNW in August 2000 as a professor for Information Systems.

The continuous alignment of business and IT in a rapidly changing environment is a grand challenge for today's enterprises. Decision-makers use models to understand and analyze a situation, to compare alternatives, and to find solutions. While humans prefer graphical or textual models, semantic annotation makes the knowledge in models machine-interpretable. The approach has been applied in the CloudSocket project for the selection of cloud services to achieve Business Process as a Service. This presentation also describes a meta-modelling approach, which combines human-interpretable graphical enterprise architecture models with machine-interpretable enterprise ontologies. A metamodel which is represented as a formal ontology determines the semantics of the metamodel. Every time a new modelling element is created during modelling, an instance for the corresponding class is created in the ontology. Thus, models for humans and machines are based on the same internal representation.



Contact:

Prof. Dr. Knut Hinkelmann
knut.hinkelmann@fhnw.ch

NEMO 2023 Summer School - Programme Overview

Week 1	13 - 14 July	17 July	18 July	19 July	20 July	21 July	
08:45 - 09:00	ADOXX TRAINING DAYS	Opening	The Role of Requirements in the Digital Age: Requirements Engineering Revisited	Modelling Temporal Requirements of Processes	Ontology-based Enterprise Modelling for Human and Machine Interpretation	The Industrial Transition towards Smart PSS: Enterprise Modelling to Support Value Creation Processes	
09:00 - 10:00		Practical Aspects of Implementing Digitalization <i>J. Coyne</i>	M. Glinz	J. Eder	K. Hinkelmann	X. Boucher	
10:00 - 11:00		Conceptual Models: Instruments for Digital Ecosystem Development <i>H.C. Mayr</i>	Multi-Level Modeling with the FMML: Integrated Design and Execution <i>U. Frank</i>	Health and Wellbeing Ecosystem of the Future: Person-Empowerment, Compliance and Governance <i>M. Helfert, M. Alfano</i>	Value Modelling for Ecosystem Design: An e3value Primer and Application Scenarios <i>S. de Kinderen</i>	Service Engineering Models for the Design and Development of Digitalized Product-Service-Systems <i>G. Pezzotta</i>	
11:00 - 11:30		B R E A K		N E T W O R K I N G		B R E A K	
11:30 - 12:30		From Requirements to Code: Conceptual Model-based Software Design <i>O. Pastor</i>	Japanese Creative Service as a Next Generation Enterprise Modelling <i>Y. Hara</i>	Integrating and Explaining Decision Models <i>J. Vanthienen</i>	Organizational Capability for Information Management: Do we feel a Big Data Crisis? <i>I. Lukovic</i>	The OMiLAB NPO: An Introduction <i>K. Hinkelmann, W. Utz</i>	
12:30 - 14:00		L U N C H		L U N C H		L U N C H	
14:00 - 15:00		Tracing the Essence of Metamodelling <i>V. Döller</i>	Business Innovation with AI - Potential, Cases and Methods <i>K. Sandkuhl</i>	Holistic Data Management and Semantic Interoperability in Historical Research <i>P. Fafalios, Y. Marketakis</i>	Towards Modelling-based Process-oriented Quality Management for Environmental Sustainability <i>F. Johannsen</i>	The Transformation of Hilti's Software Support to Customer Advocates <i>M. Müller</i>	
15:00 - 16:00		How Metamodelling Supports Digitalization <i>D. Karagiannis</i>	No-coding Approach for Business Logic Modelling <i>M. Pankowska</i>	Process Algebra to Model Probabilistic Behavior of Smart IoT <i>M.K. Lee</i>	Challenging the Design of Digital Products and Services with Modelling Approaches <i>M. Nemetz</i>	The Open-Source Software: Scene2Model and CM Tools <i>C. Muck, D. Mohammadi Amlashi</i>	
16:00 - 16:30		B R E A K		N E T W O R K I N G		B R E A K	
16:30 - 17:30		Get Together Open End	ADOxx Best Practice Develop and use conceptual models with Bee-Up® <i>P. Burzynski</i>	Practice Session Digitalization in Smart Cities with ADOxx® <i>OMiLAB@UNIVIE Team</i>	Practice Session Digitalization in Smart Cities with ADOxx® <i>OMiLAB@UNIVIE Team</i>	The Community of Practice: Focus on Skills and Cases <i>I. Vaidian, A. Völz</i>	

Week 2	22- 23 July	24 July	25 July	26 July	27 July	28 July	
09:00 - 10:00	LEISURE DAYS	Knowledge Graphs for Semantics-driven Systems Engineering <i>R. Buchmann</i>	Enterprise Modelling and Blockchains: Recent Findings and Future Prospects <i>H.G. Fill</i>	Business Processes as a Driver for Digital Transformation within Business Communities <i>A. Oberweis</i>	Capability Oriented Requirements Engineering <i>E. Kavakli</i>	GROUP PRESENTATIONS Innovation Scenarios	
10:00 - 11:00		Explore Knowledge Graphs for Systems Engineering <i>A.-M. Ghiran</i>	Data Asset Monetization as a Modelling Concern <i>M. Rossi</i>	Improving Communication between IT and Business <i>F. Moser</i>	Managing ship arrivals in a port: The Design Process of Interactive Application Software <i>H. Züllighoven</i>	GROUP PRESENTATIONS Innovation Scenarios	
11:00 - 11:30		B R E A K		N E T W O R K I N G		B R E A K	
11:30 - 12:30		Digital Leaders: Innovate Business Models <i>OMiLAB@UNIVIE Team</i>	Digital Leaders: Engineer IoT Environments <i>OMiLAB@UNIVIE Team</i>	Digital Leaders: Realize CPS Applications <i>OMiLAB@UNIVIE Team</i>	Digital Leaders: Showcase Results <i>OMiLAB@UNIVIE Team</i>	GROUP PRESENTATIONS Innovation Scenarios	
12:30 - 14:00		L U N C H		L U N C H		L U N C H	
14:00 - 15:00		Enterprise Modeling as a Knowledge Source in Systems Engineering <i>M. Kirikova</i>	Understanding Enterprise Modelling Practices <i>E. Proper</i>	Pre-Conceptual Modeling for Exploring Actors and Interactions in Real-World Systems <i>S. Vössner</i>	Embracing Imperfection in Enterprise Models <i>H. Florez</i>	GROUP PRESENTATIONS Innovation Scenarios	
15:00 - 16:00		The ITLingo RSL Language and its support by the ITLingo-Cloud Platform <i>A. Rodrigues da Silva</i>	How to Model Fair Ecosystems? <i>J. Gordijn</i>	Explore Business Ecosystems with EcoViz <i>S. Vössner</i>	PhD Research and Beyond within EIS: Trials and Tribulation <i>P. Loucopoulos</i>	GROUP PRESENTATIONS Innovation Scenarios	
16:00 - 16:30		B R E A K		N E T W O R K I N G		B R E A K	
16:30 - 17:30		Improving Agility in the Post-mass Customization Era <i>K. Medini</i>	Working Session Innovation Scenarios <i>Group Work</i>	Working Session Innovation Scenarios <i>Group Work</i>	Working Session Innovation Scenarios <i>Group Work</i>	Closing Ceremony	

VALUE MODELLING FOR ECOSYSTEM DESIGN: AN E3VALUE PRIMER AND APPLICATION SCENARIOS

Prof. Dr. Sybren de Kinderen, Eindhoven University of Technology, The Netherlands

ABSTRACT

Value modeling has been a staple of the enterprise modeling discipline for the design of value networks. E3value is historically a prominent technique for value modeling. For a given scenario it focuses on modeling the involved actors and what they exchange of value with each other. In this talk, I will introduce e3value, and reflect upon lessons learned from its application to domains as diverse as the electricity sector and the healthcare sector. Lessons learned include situational adaptation of e3value, as well as the need to embed the language in a larger suite of modeling languages such as ArchiMate to increase the potential of analyses that involve cross-cutting different organizational perspectives, which characterizes enterprise modeling.

Sybren de Kinderen is an Assistant Professor in the Information Systems group at Eindhoven University of Technology. His research interests include enterprise (architecture) modeling, (future) energy systems, and cognitive linguistics for discourse analysis in the field of information systems. Sybren holds a PhD in computer science from the Free University in Amsterdam (2010). In a previous capacity he has acted as a postdoctoral researcher at the Luxembourg Institute of Science and Technology, the University of Luxembourg, and the University of Duisburg-Essen.



Contact:

Prof. Dr. Sybren de Kinderen
s.d.kinderen@tue.nl

ORGANIZATIONAL CAPABILITY FOR INFORMATION MANAGEMENT – DO WE FEEL A BIG DATA CRISIS?

Prof. Dr. Ivan Lukovic, University of Belgrade, Serbia

ABSTRACT

Ivan Luković received his diploma degree (5 years) in Informatics from the Faculty of Military and Technical Sciences in Zagreb in 1990. He completed his M.Sc. (former Mr, 2 years) degree at the University of Belgrade, School of Electrical Engineering in 1993, and his Ph.D. at the University of Novi Sad, Faculty of Technical Sciences in 1996. Currently, he works as a Full Professor at the Faculty of Organizational Sciences of the University of Belgrade, where he lectures in several Computer Science and Informatics courses. His research interests are related to Database Systems, Business Intelligence Systems, and Software Engineering. He is the author or co-author of over 200 papers, 4 books, and 30 industry projects and software solutions in the area. He supervised 12 completed Ph.D. theses. He created a new set of B.Sc. and M.Sc. study programs in Information Engineering, i.e. Data Science, at the Faculty of Technical Sciences. The programs were accredited the first time in 2015. Currently, he is a chair of Managing Board of the Computer Science and Information Systems (ComSIS) journal, and a chair of M.Sc. study program in Information Engineering at Faculty of Organizational Sciences. He is also a member of Serbian AI Society.



Contact:

Prof. Dr. Ivan Lukovic
ivan.lukovic@fon.bg.ac.rs

ABSTRACT

Nowadays, modern business includes acquisition and store of enormous data volumes, larger than ever before. Most often, collected data are used in a shorter time frame, and then they are archived and almost not used, effectively. On the other hand, such data represent a significant value that a company can utilize so as to reach created goals and provide a sustainable development. Unfortunately, a daily practice in many companies still intensively points out to the problem of a serious gap between the identified needs for knowledge, on one hand, and inability of modern software products to address such needs in an effective way, on the other hand. Despite that massive data volumes already exist and that modern information solutions provide the excellent technology prerequisites for a development and industry implementation of high quality software applications. We can call such a phenomenon a "big data crisis". Some of important causes of the aforementioned phenomenon are in the following: (1) Unsatisfactory level of organization maturity in regard to the: capabilities for information management, quality management, and business processes; (2) Unsatisfactory level of accumulated knowledge in a problem domain; and (3) Unsatisfactory level of accumulated knowledge in a domain of software engineering, particularly in a domain of the development and formal specification of models for software products aimed at generation of company knowledge and decision support. Alleviating the aforementioned phenomenon is a strategic and long term task, possible by simultaneous addressing all its significant causes, only. In this talk, some of the author's research and educational efforts will be presented, trying to address the most influencing factors for information management and innovations, leading to the digital transformation process.

TOWARDS MODELING-BASED PROCESS-ORIENTED QUALITY MANAGEMENT (PQM) FOR ENVIRONMENTAL SUSTAINABILITY

Prof. Dr. Florian Johannsen, Hochschule Schmalkalden, Germany

ABSTRACT

An important climate target recently established by the EU is a 55% decrease in greenhouse gas emissions (by 2030), with the goal of achieving complete climate neutrality by 2050. Considering this, companies need to critically reflect upon their business processes and aim to reduce greenhouse gas emissions as well as energy and resource utilization. At that point, process-oriented quality management methods like Six Sigma or Lean Management can make substantial contributions in reorganizing a company's processes to meet environmental goals and come to resource-saving operations. The issue is that a standardized definition of "green quality" along with corresponding quality dimensions has not yet established. Accordingly, companies search for ways to adapt, modify, or enhance existing quality management methods to pursue different sustainability goals. In this light, the lecture proposes an approach to construct enterprise-adapted and easy-to-use quality management approaches to pursue environmental sustainability goals on a process level. Thereby, conceptual model types are used to document, process and communicate the results generated in projects.

Florian Johannsen holds the position of a professor for "Enterprise Information Systems" at the University of Applied Sciences Schmalkalden. Until March 2019 he was a visiting professor for Industrial Services in the "Department of Economics" at the University of Bremen. He successfully completed his habilitation in October 2017 and was appointed "private lecturer (Privatdozent)" at the University of Regensburg. He received his doctoral degree at the University of Regensburg in March 2011, where he worked as a research assistant and postdoctoral researcher from 2006 to 2017. During that time, he led several projects with partners from industry and published his research at highly regarded conferences and in reputable journals. Since the beginning of 2023 he runs the OMILAB Node "Conceptual Modelling for Process-oriented Quality Management" at his university.



Contact:

Prof. Dr. Florian Johannsen
f.johannsen@hs-sm.de

CHALLENGING THE DESIGN OF DIGITAL PRODUCTS AND SERVICES WITH MODELLING APPROACHES

Dr. Martin Nemetz, HILTI AG, Liechtenstein

ABSTRACT

Martin Nemetz holds a PhD in Business Informatics from the University of Vienna and has worked for the Hilti Corporation since 2008. Initially, he was a Project Manager for diverse ERP-driven projects. In 2012, Martin was appointed the Head of the Competence Center for on Demand and on Device Services. Martin led his team in defining the way forward for IT in Hilti by evaluating the latest technologies and IT trends such as mobility, cloud services, and social media while checking their applicability for business support and usage. Since 2012, Martin became part of the Hilti IT Leadership Board. In 2015, Martin relocated to Malaysia to further expand and develop the Asia talent hub in Kuala Lumpur - Hilti Asia IT Services as one of the three strategic Global IT locations in Hilti. In this role, his portfolio covers the people, landscape, applications, technologies and the resulting digital transformation. Together with his team, Martin focuses hereby on two-dimensional growth - team size as well as technological and business competence.

Hilti is providing products, system solutions and software-based services that contribute to make work on construction sites simpler, faster and safer. While Hilti is proud of its leading construction tools and consumables, it has started to engage itself in building digital products and solutions for its customers. In our presentation at NEMO Summer School, we describe how modelling approaches help us in building software solutions that satisfy the needs of our customers. Relevant questions herein are: (1) How do we reduce the variations and hence complexity of provided software features so that we can deliver them fast and in a reliable manner without compromising customer needs? (2) How can we consider future scaling and performance needs in our software architecture? (3) How can we achieve an architecture model that allows for identifying potential issues (or improvement needs) before they impair our software solutions? We work on trying to answer these and other questions by (also) applying modelling approaches in a pin-pointed and efficient way.



Contact:

Dr. Martin Nemetz
Martin.Nemetz@hilti.com

THE INDUSTRIAL TRANSITION TOWARDS SMART PRODUCT-SERVICE-SYSTEMS: ENTERPRISE MODELLING TO SUPPORT VALUE CREATION PROCESSES

Prof. Dr. Xavier Boucher, École des Mines de Saint-Étienne, France

ABSTRACT

The current industrial transition towards Factories of the Future (FoF) implies strong transformation of enterprise Business Models within the manufacturing sector. Product Service Systems are a key component of this transition, and contribute to renovate both the underlying enterprise models and the needs of enterprise engineering tools. The objective of the lecture is to articulate the overall needs of transition towards FoF with the requirements for innovative conceptual modelling approaches and new enterprise engineering methods and tools. The lecture will first give a synthetic insight on PSS within the context of FoF, to make possible for the audience to understand the key concepts of PSS and key industrial needs for developing innovative enterprise modelling and engineering solutions. The second part of the lecture articulate two dimensions of Enterprise engineering: an advanced modelling method dedicated to support PSS design and engineering (based on a PSS-oriented meta-model) and a decision-making approach for PSS economic-model balancing.

Xavier Boucher is Professor in Industrial Management at the Ecole des Mines de Saint Etienne (France). He is Research Director at FAYOL Institute, a research Center focusing on Sustainable Industrial performance and Organisations. His current research focuses on Product Service Systems (PSS), Service oriented production systems, collaborative-agile networks and decision models to manage the supply chain agility. Prof. X. Boucher is currently leading several collaborative research projects in the field of design and management of PSS with an economic and manufacturing point of view.



Contact:

Prof. Dr. Xavier Boucher
boucher@emse.fr

SERVICE ENGINEERING MODELS FOR THE DESIGN AND DEVELOPMENT OF DIGITALISED PRODUCT-SERVICE SYSTEMS

Assoc. Prof. Giuditta Pezzotta, University of Bergamo, Italy

ABSTRACT

Giuditta Pezzotta is Associate Professor at the Department of Management, Information and Production Engineering and Vice Chancellor for Quality Assurance at University of Bergamo. She received her PhD degree in Management, Economics and Industrial Engineering from Politecnico di Milano in 2010. During her PhD studies, she was a visiting PhD student at DIAL - Institute for Manufacturing - University of Cambridge in UK. Her PhD was in the Service Engineering and Product Service System fields. She has also been visiting researcher at the University of Botswana, Tokyo Metropolitan University and Blekinge Institute of Technology. She carries out her research activities interested in the design, engineering and management of product-service systems and in modeling and simulation of production and service delivery processes. Through her work at the University of Bergamo she has been involved and has coordinated several industrial and research projects related to the Product-Service field. She is author of more than 100 refereed international and national journal and conference papers. Since 2019, she is co-coordinator of the Special Interest Group (SIG) in Service Systems Design, Engineering and Management of IFIP. She is part of the Scientific committee of "Centro interuniversitario di ricerca sull'innovazione e la gestione dei servizi nelle imprese industriali" (<http://www.asapsmf.org/>).

Despite their recent introduction and consolidation in the industrial practice, Product Service System business models are subjected to a further revision in order to fully exploit the opportunities and challenges provided by the Industry 4.0 technological paradigm. Companies need to identify and define new business models integrating PSS with digital technologies and, as a result, revise their decision-making processes. The design and development of a Product-Service System (PSS) raises new issues since the service component introduces further requirements than traditional product engineering. Compared to traditional and smart products, services are generally under-designed and inefficiently developed. Approaches such as New Service Development, Service Design and Service Engineering have emerged during the last decades to support the design and development of service either as a system itself or as a constituting element of a PSS. In particular, Service Engineering investigates service design and development with a systematic perspective and with a seamless integration of product and service contents. Purpose of the lecture is to provide a holistic conceptualisation and an up-to-date analysis of the current state of the art on the evolution of the concept of Product Service system and Service Engineering models with a specific focus on their adoption in the PSS context. A critical analysis is also performed with the aim to define a research agenda and the most prominent key actions that could give directions for future research.



Contact:

Assoc. Prof. Giuditta Pezzotta
giuditta.pezzotta@unibg.it

KG4SDSE: KNOWLEDGE GRAPHS FOR SEMANTICS-DRIVEN SYSTEMS ENGINEERING

Prof. Dr. Robert Buchmann, Babes-Bolyai University, Romania

ABSTRACT

Knowledge Graphs have been primarily investigated as engineered artifacts by themselves – from their underlying formalisms (e.g. description logics), enabling technologies (e.g. RDF, LPG) to their knowledge management and semantic enrichment capabilities. We aim to shift focus from what Knowledge Graphs are or how they can be built towards how they can be relevant to Information Systems engineering. We also aim to investigate their place in the Conceptual Modeling paradigm, specifically how Knowledge Graphs can enable new flavors of model-driven engineering or low-code engineering. Research advances on the interplay between Knowledge Graphs and Machine Learning or Natural Language Processing for systems engineering purposes are also discussed.

Robert Andrei Buchmann received his doctoral degree in the field of E-commerce application models from Babeş-Bolyai University of Cluj Napoca, Romania, in 2005. Since then, he has been specializing in Semantic Technology and Conceptual Modelling, as enablers for Knowledge Management Systems and Enterprise Architecture Management. During 2012-2015 he occupied a postdoctoral research position at University of Vienna, specializing in Agile Modelling Method Engineering, while managing metamodelling and requirements engineering tasks for the ComVantage FP7 project. Currently, he occupies a Professor position at Babeş-Bolyai University and is the Scientific Director of the University's Business Informatics Research Center, where his team is investigating opportunities of interplay between the paradigms of Semantic Web, Enterprise Modelling and Requirements Engineering.



Contact:

Prof. Dr. Robert Buchmann
robert.buchmann@econ.ubbcluj.ro

EXPLORE KNOWLEDGE GRAPHS FOR SYSTEMS ENGINEERING

Prof. Dr. Ana-Maria Ghiran, Babes-Bolyai University, Romania

ABSTRACT

Ana-Maria Ghiran has research experience with the Semantic Web technological space, as she had applied it in her own doctoral thesis developed at Babeş-Bolyai University of Cluj Napoca, in the field of IT Infrastructure Auditing. She has been involved in teaching and developing the „Information Systems Security“ and „Semantic Web“ disciplines for the Business Information Systems Department at the same university. Currently she is investigating the Conceptual Modeling paradigm and applications of semantic technology in model-driven software engineering.

The Digital-first Era imposes a shift from the conventional System Engineer working with system blueprints, towards a Digital Engineer profile which includes the ability to incorporate in the engineered artifacts semantics from the application domain, about goals, resources, and business processes. For conceptual models, this implies a shift from a representation to a mediation role, and Knowledge Graphs (KG) are a technological ingredient that can facilitate this shift. This presentation will focus on practical examples suggesting new flavors of model-driven engineering that become possible when diagrammatic models and knowledge graphs work together towards achieving semantic enrichment that becomes available to even the simplest software artifacts, e.g. Web pages built with traditional means (PHP, HTML). In the showcased approach, the Digital Engineer can use conceptual modelling to capture diverse semantic facets of an enterprise and to streamline those to engineering activities. The demonstration will include introductory hands-on practice - first with semantic graph queries and reasoning on generic minimalist semantic graphs, followed by demonstrations of the semantic enrichment capabilities found in the Bee-Up modelling tool.



Contact:

Prof. Dr. Ana-Maria Ghiran
anamaria.ghiran@econ.ubbcluj.ro

ENTERPRISE MODELING AS A KNOWLEDGE SOURCE IN SYSTEMS ENGINEERING

Prof. Dr. Marite Kirikova, Riga Technical University, Latvia

ABSTRACT

In an era of global economy and frequent changes caused by digital transformation, innovation, and other factors, the systems development faces the need for continuous realignment with new enterprise goals, business processes, and technologies. To achieve a successful realignment, availability of knowledge about the enterprise and its environment (including new technologies) becomes an enabler of successful definition of requirements and implementation of changes at the business and technology level. Enterprise models are an important source of knowledge that can be represented using commonly available enterprise architecture notations. Sticking to common notations helps not only to represent the knowledge about the enterprise but also to show a generic knowledge about new technologies, for instance, low-code/no-code development; and such representation, in turn, helps in the adoption of these technologies.

Mārīte Kirikova is a Professor in Information Systems Design at the Department of Artificial Intelligence and Systems Engineering, Faculty of Computer Science and Information Technology, Riga Technical University, Latvia. She has more than 200 publications on the topics of requirements engineering, business process modelling, knowledge management, systems development and educational informatics. She is also a co-editor of several scientific proceedings in the area of databases, information systems, information systems engineering, enterprise modelling, systems and business, and business informatics. Marite Kirikova has participated in university research and teaching teams in Sweden, Denmark, Austria, and USA. In her research currently she focuses on continuous information systems engineering in the context of agile and viable system paradigms.



Contact:

Prof. Dr. Mārīte Kirikova
Marite.Kirikova@cs.rtu.lv

THE ITLINGO RSL LANGUAGE AND ITS SUPPORT BY THE ITLINGO-CLOUD PLATFORM

Prof. Dr. Alberto Rodrigues da Silva, Instituto Superior Técnico, Universidade de Lisboa, Portugal

ABSTRACT

Alberto Manuel Rodrigues da Silva is Professor at the Department of Computer Science and Engineering (DEI), Instituto Superior Técnico, Universidade de Lisboa (IST-UL), and Integrated Researcher at INESC-ID Lisboa. He has researched on the topics of information systems, software engineering, model-driven engineering, requirements engineering, document automation, and project management, and their application in multiple domains. He was partner and director of the company SIQUANT, having coordinated several projects, highlighting the virtual reality system of Serra da Estrela and of Sintra Cascais Natural Park, the Trails and Interpretation Portal, or the GestBarragens, a dams safety management system largely adopted by Portugal and Angola authorities. He is currently the coordinator/leader of the Information and Decision Support Systems Lab of INESC-ID. He has authored 5 technical books and 200+ publications in journals, conferences, and workshops with peer review, and he has edited 5 scientific books. He was included in the list of the 2% of scientists with the most influential career in 2021 by Stanford University.



Contact:

Prof. Dr. Alberto Rodrigues da Silva
alberto.silva@tecnico.ulisboa.pt

ABSTRACT

Several surveys and studies have noticed that cost, and quality problems result from mistakes that occurred in the early phases of the projects. These facts have emphasized the need for improving socio-technical disciplines such as project management, enterprise architecture, requirements engineering, or system design. These studies also noted the need to reduce the efforts involved in traditional development processes, for example, by automating some human-intensive and error-prone tasks. This talk introduces the scientific project we have conducted in these last years named "ITLingo". ITLingo is a research initiative that has proposed new languages, tools, and techniques to support users to improve such practices, mainly related to those disciplines. ITLingo users are IT engineers and managers in multiple roles like project managers, enterprise architects, business analysts, system architects, requirements engineers, or even system developers. The talk presents the innovative nature of these activities and presents in more detail the RSL language (a controlled natural language for requirements and testing specification) and its support by the ITLingo-Cloud. The ITLingo-Cloud is a collaborative web platform that allows its users to create and manage their own workspaces and includes a collaborative online IDE (like VS-Code) for supporting the authoring of rigorous RSL specifications or in similar languages.

IMPROVING AGILITY IN THE POST-MASS CUSTOMIZATION ERA

Prof. Dr. Khaled Medini, École des Mines de Saint-Étienne, France

ABSTRACT

Agile manufacturing has been around for a while as a means to address changing customer requirements and turbulent markets. Among the critical challenges ahead of decision makers in the business sector, is how to deploy agility concepts at operational level. This lecture introduces agility concept with a focus on manufacturing domain and outlines solutions approaches to enable agile manufacturing. The lecture also highlights the role of business process management in fostering the deployment of agile manufacturing.

Khaled Medini is currently an Associate Professor at the Mines Saint-Etienne; he holds a PhD and a Research Habilitation (HDR) in Industrial Engineering. He is Certified Project Management Professional (PMP®). His current research interests include agile and sustainable manufacturing and digitalisation. He is an associate editor of the Engineering Management Speciality Section of Frontiers in Industrial Engineering, editorial board member of Systems and of the International Journal of Supply Chain and Inventory Management. He is a member of the scientific committees of several international conferences, most of which are sponsored by International Federation for Information Processing (IFIP) or CIRP (International Academy for Production Engineering). He is a member of International Federation of Information Control (IFAC T5.3). He served as an external member of PhD and MSc committees. He has been involved as principal investigator or project manager in several research projects.



Contact:

Prof. Dr. Khaled Medini
khaled.medini@emse.fr

ENTERPRISE MODELING AND BLOCKCHAINS: RECENT FINDINGS AND FUTURE PROSPECTS

Prof. Dr. Hans-Georg Fill, University of Fribourg, Switzerland

ABSTRACT

Hans-Georg Fill is full professor at the University of Fribourg, Switzerland and head of the Research Group Digitalization and Information Systems. He holds a PhD and a habilitation from the University of Vienna in business informatics. He was a visiting researcher at Stanford University, USA, Karlsruhe Institute of Technology, DE and Ecole Nationale Supérieure des Mines at St. Etienne, FR. His research activities focus on the development of IT-based modelling tools, distributed ledger technologies, visualization, and the alignment of conceptual modelling and semantic technologies.

Blockchains constitute a technology that became popular through the success of Bitcoin and other cryptocurrencies. Besides these applications, the underlying technologies provide interesting opportunities for new types of business models and applications that benefit from transparency and decentralization in potentially untrusted environments. In this lecture we will explore how enterprise modeling can be used in this context. In particular we will review recent approaches for combining enterprise models and blockchain technologies and how such combinations may be realized technically.



Contact:

Prof. Dr. Hans-Georg Fill
hans-georg.fill@unifr.ch

DATA ASSET MONETIZATION AS A MODELING CONCERN

Prof. Dr. Matti Rossi, Aalto University, Finland

ABSTRACT

Although data as a new sellable good has been under discussion for years, selling and monetizing data assets has not been given proper thought in IS modeling and development. This aspect is of relevance given recent concerns about data privacy and security and the simultaneous explosion in the use of data for marketing and service-development purposes. We show how this aspect can be considered in IS development through constraints (organization type, business type, data characteristics, privacy, and security) that companies should address to move from the internal use of data and supporting existing customers to generating new business through selling data. These concerns need to be linked to data production processes within the organization and analyzed against regulations (e.g. GDPR and new European DMA and DSA acts). Furthermore, through the DMA and DSA acts EU moves towards a fair data economy, which will be a key concern about data assets in the near future. We also demonstrate how business models can be used to analyze what parts of the data assets can be monetized and what kind of relationships and partnerships have to be formed.

Matti Rossi is a professor of information systems at Aalto University School of Business. He is a past president of the Association for Information Systems and AIS Fellow. He has been the principal investigator in several major research projects funded by the technological development center of Finland and Academy of Finland. He was the winner of the 2013 Millennium Distinction Award of Technology Academy of Finland for open source and data research. His research papers have appeared in journals such as MIS Quarterly, Journal of AIS, Information and Management and Information Systems. He has been a senior editor of JAIS and Database, and an associate editor for MIS Quarterly, and he is the past editor in chief of Communications of the Association for Information Systems.



Contact:

Prof. Dr. Matti Rossi
Matti.rossi@aalto.fi

UNDERSTANDING ENTERPRISE MODELLING PRACTICES

Prof. Dr. Erik Proper, TU Wien, Austria

ABSTRACT

Henderik A. Proper, Erik for friends, is Full Professor in Enterprise and Process Engineering in the Business Informatics Group at the TU Wien. Erik has a mixed background, covering a variety of roles in both academia and industry. His core research drive is the development of theories that work. In other words, Erik focuses on research that leads to results that have both theoretical rigour and practical relevance. His general research interest concerns the foundations and applications of domain modelling; in particular in the context of enterprises. Over the past 20 years, he has applied this research drive and general research interest towards the further development of the field of enterprise design management, and enterprise modelling in particular. He is also co-initiator of the ArchiMate research project, which also resulted in the ArchiMate standard for enterprise architecture modelling. Erik is vice-chair of the IFIP 8.1 working group, while also being the representative for the Netherlands in IFIP's TC8 technical committee. He is also the Stellvertretender Sprecher (vice chair) of the EMISA working group of the German Computer Science Society (Gesellschaft für Informatik).



Contact:

Prof. Dr. Erik Proper
henderik.proper@tuwien.ac.at

ABSTRACT

Humanity has long since used models in different shapes and forms to understand, redesign, communicate about, and shape, the world around us; including many different social, economic, biological, chemical, physical, and digital aspects. This has resulted in a wide range of modeling practices that can be found across society. When the models as created and used in such modeling practices have a key role to play in the activities in which these modeling practices are 'embedded', the need emerges to consider the effectiveness and efficiency of such processes, and actually speak about modeling capabilities. Models (also) play a natural role in the (continuous) development, operation, and regulation of enterprises. Even more, new technologies, such as AI, low-code, rule engines, IoT, Digital Twins, etc, provide additional drivers and enablers for the (critical) usage of models in enterprises. As a consequence, modeling capabilities have become a crucial (often hidden) part of both the dynamic capabilities and the operational capabilities of enterprises. This makes it relevant to develop a thorough understanding of the artifacts involved in the modeling practices/capabilities in general, and in the context of enterprises in particular. This includes, the notion of model itself, conceptual fidelity of a model, and views. In this lecture we, therefore, explore these cornerstones of modeling practices in general, and in the context of enterprises in particular.

HOW TO MODEL FAIR ECOSYSTEMS?

Prof. Dr. Jaap Gordijn, Vrije Universiteit Amsterdam, The Netherlands

ABSTRACT

Many ecosystems such as Facebook, Google, Amazon, Uber, and many more are not considered as fair. This is amongst other demonstrated by the European Commission, who fines the dominant parties of these ecosystems regularly. We explain, in a model-based way why such ecosystems are unfair, and how the model can tell this. We also give some guidelines how to design fair ecosystems and the required decentralized information technology to accomplish these. We also give some examples of ecosystems that are from a structural point fairer than the well-known platform-oriented ecosystems.

Jaap Gordijn is founder and director of The Value Engineers, a company delivering a methodology and associated software tooling for the design and analysis of complex digital ecosystems. Also, he is the UNESCO chair of the Decentralized Information Society Engineering (DISE) research group at VU Amsterdam, The Netherlands. Also, Jaap is visiting professor at the University of Malaysia, UNIMAS. He is the key developer of, and has internationally published on, the e3-value methodology, which comprises a graphical technique to design and evaluate networked business models (www.e3value.com). Earlier, he was a member of Cisco's International Internet Business Solution Group. As such, he was active as an e-business strategy consultant in the banking, insurance, and digital content industries.



Contact:

Prof. Dr. Jaap Gordijn
j.gordijn@vu.nl

BUSINESS PROCESSES AS DRIVER FOR DIGITAL TRANSFORMATION WITHIN BUSINESS COMMUNITIES

Prof. Dr. Andreas Oberweis, Karlsruhe Institute of Technology, Germany

ABSTRACT

Andreas Oberweis is professor at the Karlsruhe Institute of Technology (KIT), Institute of Applied Informatics and Formal Description Methods. He is Research Director and Member of the Board of FZI Research Center for Information Technology Karlsruhe. He is co-founder of several companies in the field of Business Process and Software Engineering.

Business processes in the age of the internet are typically not restricted to single organizations but cross organizational borders to customers, suppliers and other organizations. The design of business processes for these business communities is a complex collaborative task, which requires special methodological support. This course introduces Horus, which includes a set of modeling methods and languages to support the whole life cycle of business processes within business communities. Horus is based on high-level Petri Nets for procedure modeling and provides additional modeling support for objects, resources, organizational structures, business goals and business rules. Simulation based concepts are provided to evaluate models. Besides describing the basic concepts of Horus, the course also gives an overview about ongoing research work.



Contact:

Prof. Dr. Andreas Oberweis
andreas.oberweis@kit.edu

IMPROVING COMMUNICATION BETWEEN IT AND BUSINESS

Frank Moser, United Nations Geneva, Switzerland

ABSTRACT

This talk is non-academical and will focus on the communication challenge between IT and business, notably between IT and decision makers. IT leaders tends to present to stakeholders too much technical and detailed information while neglecting the business context and other important interdependencies. Due to this communication obstacle, business decisions are often made based on incomplete and irrelevant information which may lead to insufficient new systems or services or more vulnerable systems due to underfunding in cyber security. Design Thinking has been applied in practice for building new IT systems and services. The main phases of Design Thinking are: (i) empathizing (identifying user needs), (ii) defining (stating user needs and problems), (iii) ideating (creating ideas), (iv) prototyping (start to build) and (v) testing. Design Thinking per se is a very visual approach which can be easily understood by non-IT and it is a powerful tool for enabling effective discussions among different business units composed of people with different backgrounds and skills. During my sabbatical leave, I have identified Design Thinking as a framework for identifying, assessing and mitigating potential cyber security challenges at an early design change, e.g. the phase of (ii) defining can be extended to "defining" potential exploration of the solution by an adversary. In this regard Design Thinking is a way towards the support of the principle of "Security-By-Design". In my presentation, I will present some practical examples.



Contact:

Frank Moser
moserf@un.org



Frank Moser has been graduated from University of Mannheim in Business Informatics in 1992. After a three-year research assignment in multimedia systems at a research institute, he entered the United Nations Secretariat through a competitive examination process. He worked at several UN organizations such as the Office of the High Commissioner for Human Rights (OHCHR), the Economical Commission for Europe (ECE), the Department of General Assembly and Conference Management (DGACM), and the International Atomic Energy Agency (IAEA) in tree duty stations (Geneva, New York and Vienna) and in CIO and CISO roles. Currently, he is on sabbatical leave and will return to his role in the conference service at the UN Office at Geneva, in charge of printing, distribution, design, multimedia and IT.

PRE-CONCEPTUAL MODELING FOR EXPLORING ACTORS AND INTERACTIONS IN REAL WORLD SYTEMS

Prof. Dr. Siegfried Vössner, Technical University of Graz, Austria



ABSTRACT

Siegfried Vössner holds a PhD degree in Engineering Sciences from Graz University of Technology. Until 1999 he was a postdoctoral fellow and visiting scholar at the Department for Engineering Economic Systems and Operations Research at Stanford University, USA. After being a project manager for McKinsey&Company he became professor and chairman of the institute of Engineering- and Business Informatics in 2003 and was Vice-Dean of the School of Mechanical Engineering and Economic Sciences of Graz University of Technology from 2004-2015 and holds this position again since 2020. He has been a visiting professor at Stanford University, the Naval Postgraduate School in Monterey and at the University of Auckland in New Zealand and is an alumnus of the Strategic Leadership Program from Austrian National Defense Academy. His research interests are: Modeling and Simulation of Business and Social Systems, Systems Architecture and System Engineering, Public Safety and Systems Safety, Critical Infrastructure, Production Systems – Design, Operations, Optimization.



Contact:

Prof. Dr. Siegfried Vössner
voessner@tugraz.at

When modeling real world activities involving social, economic and technical aspects conceptual modeling is a necessary prerequisite to set the stage and define the system boundaries, which becomes difficult - especially when not all relevant actors, shareholders and stakeholder as well as their intrinsic and extrinsic motivations are known. One of the methodological challenges is to provide a unified framework to collect as many relevant perspectives and pieces of information and create a most comprehensive but yet insightful and understandable representation. Another challenge is to transform these findings into standardized and re-usable information which can serve as input for other modeling tools downstream in the tool chain. We will present both a methodology based on value networks and a modeling tool (EcoViz), which is intended to address these issues and can also be used right before the typical conceptual modeling starts - in a "pre- conceptual phase" and show some practical applications.

CAPABILITY ORIENTED REQUIREMENTS ENGINEERING

Prof. Dr. Evangelhia Kavakli, University of the Aegean, Greece

ABSTRACT

The lecture concerns an approach to the application of conceptual modelling known as the Capability Oriented Requirements Engineering (CORE) approach. The conceptual modelling framework applied in CORE employs a set of complimentary and intertwined modelling paradigms based on enterprise capabilities, goals, actors, and information objects. The lecture will define the foundational concepts of CORE as well as the way of working from capturing textual descriptions from stakeholders, progressing to formally defining models of early requirements, based on the CORE meta-model, and in a stepwise refinement define functional and non-functional requirements of desired systems. The theory will be supplemented by examples from a real application of CORE on a Cyber Physical Production System.

Evangelhia Kavakli is an Associate Professor at the Department of Cultural Technology and Communication of the University of the Aegean. She obtained her PhD in Computation from the University of Manchester, Institute of Science and Technology in 1999. She is in charge of the Cultural Informatics Laboratory of the University of the Aegean. Her research on the topics of goal oriented requirements engineering, enterprise knowledge modelling, information systems privacy and cultural informatics, has been supported in the context of national and EU funded projects. Her current research focuses on requirements engineering for Big Data applications and the design of socio-cyber-physical systems. She has published over 60 peer-reviewed papers in reputed international journals and conferences and edited books. She is member of the editorial board of the Requirements Engineering Journal and has served in the program committee of a substantial number of international conferences in the field of information systems.



Contact:

Prof. Dr. Evangelhia Kavakli
kavakli@ct.aegean.gr

MANAGING SHIP ARRIVALS IN A PORT: THE DESIGN PROCESS OF INTERACTIVE APPLICATION SOFTWARE USING METAPHORS AND USER PARTICIPATION

Prof. Dr. Heinz Züllighoven, University of Hamburg, Germany

ABSTRACT

Heinz Züllighoven (born 1949) studied electrical engineering at RWTH Aachen University, then German literature and language as well as mathematics at the University of Bonn. In 1989 he received his doctorate from the Department of Computer Science at the TU Berlin. Between 1991 and 2015 he held a chair as full professor in the Software Engineering Department at the University of Hamburg. In 1994 he founded a start-up company, now WPS GmbH with Guido Gryczan and since 1999, in addition to his half-time professorship, where he acted as managing director until 2021. He still advises his former company and non-profit organizations. Heinz Züllighoven is one of the leading authors of the object-oriented tool & material approach and has published extensively on various software technology topics. The book „The Object-Oriented Construction Handbook“ on the WAM approach was published by Morgan Kaufmann.

ABSTRACT

The lecture describes the path from the task-oriented analysis of ship traffic management in the Port of Hamburg to the design and realisation of a touch table application „Sounding Table“. The focus is on supporting the arrival and departure of large ships in the Port of Hamburg. This example shows how we narrowed the classical gap between the domain-oriented analysis of the application area and the design of the user model. We will outline how design metaphors and user participation have a direct influence both on the usability and on the architecture of the software.



Contact:

Prof. Dr. Heinz Züllighoven
Heinz.Zuellighoven@wps.de

EMBRACING IMPERFECTION IN ENTERPRISE MODELS

Prof. Dr. Hector Florez, Universidad Distrital Francisco Jose de Caldas, Colombia

ABSTRACT

Enterprise models are created to represent business and Information Technologies (IT) elements and to abstract the relation between them in one enterprise under study. They provide value for an organization when they are used to support enterprise analysis. The process of constructing an enterprise model is complex and requires demanding activities such as human observation, consulting sources of different natures, and interpreting unstructured information. Thus, building an enterprise model that properly represents the enterprise has a high level of difficulty. The difficulty is based on two main reasons: 1) the enterprise size and complexity and 2) several uncontrolled factors that affect the modeling process such as sources quality and lack of information. Models represent the state of the enterprise in a given moment, but enterprises change continuously, which implies that models are inherently imprecise. Thus an enterprise model may lack complete information and even contain imprecise or inconsistent information; then, they must be refined when new information is gathered from enterprise sources. Thus, model imperfection is inevitable in enterprise models. Then, it is better to include information in the model to represent explicitly certain problems than to ignore them and assume that the model accurately represents the enterprise. Modeling the imperfection implies creating other kinds of models called imperfect models, which contain information that can assess the imperfection. Identifying and measuring the imperfection of an enterprise model can determine whether the model is useful for further purposes such as analysis.

Hector Florez received a Ph.D. in Engineering from the Universidad de los Andes (Colombia), a M.Sc. in Information and Communication Sciences from the Universidad Distrital Francisco Jose de Caldas (Colombia), and a M.Sc. in Management, from the Universidad Militar Nueva Granada (Colombia). In addition, he is Electronics Engineer, Computing Engineer, and Mathematician. He performed a Ph.D. internship at the Universitat Duisburg Essen (Germany) and attended the NEMO Summer School 2014 at the Universitat Klagenfurt (Austria). Currently, he is Full Professor at the Universidad Distrital Francisco José de Caldas (Colombia). He is the general chair of the International Conference of Applied Informatics (<https://icai.itud.org/>), guest editor of the journals SN Computer Science (<https://www.springer.com/journal/42979>), Frontiers in Computer Science (<https://www.frontiersin.org/journals/computer-science>), and associate editor of the journal CEUR Workshop Proceedings (<https://ceur-ws.org/>). His research interests are focused on (but not limited to) model-driven engineering, model analysis, and data science.



Contact:

Prof. Dr. Hector Florez
haflorezf@udistrital.edu.co

PHD RESEARCH AND BEYOND WITHIN EIS: TRIALS AND TRIBULATION

Prof. Dr. Pericles Loucopoulos, Manchester University, UK

ABSTRACT

Pericles Loucopoulos holds appointments at the School of Computer Science of the University of Manchester (UK) and at the Department of Informatics of Harokopio University of Athens (Greece). His research has been supported by numerous research grants supporting over 25 research projects, most of them in collaboration with industry. He is the editor-in-chief of the Journal of Requirements Engineering and also serves as Associate Editor on 15 other journals. His research focus is on the use of conceptual modelling for achieving alignment between enterprise and information technology systems with particular focus on requirements specification and analysis. He has developed the Enterprise Knowledge Development (EKD) and more recently the Capability Oriented Requirements Engineering (CORE) methods, both of which are part of the Open Models Initiative (OMI) platform. He is a member of a number of international professional bodies, has served as General Chair or Programme Chair of many international conferences and has served on over 300 conference programme committees. He has been awarded the Edelman Laureate medal and the President's Medal of the UK OR Society. He has authored 9 books, edited 23 books and conference proceedings and has published over 200 papers in journals and international conferences.



Contact:

Prof. Dr. Pericles Loucopoulos
periloucopoulos@icloud.com

ABSTRACT

Research has often been regarded as a “wicked problem”, an activity of informed curiosity when researchers state what they are doing when they don’t really know what they are doing. It is a process which is guided by a particular methodology the choice of which is based on the contextual setting of the research topic (the challenges) as well as the motivation for a solution (the deliverables). In this lecture, we will examine issues involved in research with particular emphasis on research in the field of Enterprise Information Systems (EIS). We will examine the issues underpinning the EIS domain, the emergence of research needs from digitisation, to interpretation and more recently to transformation of enterprises. Given this context, we will explore different research methodologies that may be deployed, such as those of Design Science Research, Action Research, Case Study, Survey Design, Mixed Methods and Qualitative Methods, each one of which is suited to different motivational characteristics of the underlying research goals. We will also explore the social dimension of research, including issues encountered by researchers in settings involving communities within their specific research environment as well as other related communities (e.g. the NEMO Summer School) and the broader EIS community. Branching out from a close research environment by exploiting gained experiences, towards collaborative initiatives, competing for research funding and helping the next generation of researchers will also be addressed in this lecture.

THE OMILAB NPO: AN INTRODUCTION

Prof. Dr. Knut Hinkelmann, OMILAB NPO, Germany
Dr. Wilfrid Utz, OMILAB NPO, Germany

ABSTRACT

In recent years, we could observe a fast-paced evolution of technologies (infrastructure, hardware, software) in a ubiquitous manner leading to a change of perception how we build, organize, and run business operations. Enterprises constantly need to reflect on a strategic level how these changing circumstances are influencing their business models, operation, and regulatory/organisational framework they operate within to stay competitive and transparently develop and adapt their roadmap for digital transformation. Consequently, innovation process are required to continuously evaluate, trigger changes and adapt to specific needs on a societal and business level. The above observation motivates this talk, introducing the Open Models Initiative Laboratory (OMILAB) that supports an active global community for conceptual modelling who benefits from open artefacts. To this end it acts as a facilitator to the development of scientific methods and technologies for all those who value models. In addition OMILAB acts as a platform, where participants can bring in ideas related to modelling and engage in the exploration process. The Digital Innovation Environment (DIEn) powered by OMILAB enables design, engineering and training activities for organisations pursuing Digital Transformation initiatives. Stakeholders from multi-disciplinary backgrounds are supported to create innovative ideas as Digital Business Models, to materialise them in proof-of-concept implementations using Digital Twins and to evaluate their feasibility in a laboratory setting as/through the OMILAB Innovation Corner, within a corporate or academic context focusing on Digital Innovation.

Knut Hinkelmann is Head of the Master of Science in Business Information Systems at the FHNW University of Applied Sciences and Arts Northwestern Switzerland. He also is visiting professor at the University of Camerino, Italy, and research associate at the University of Pretoria, South Africa. In 1988 he obtained a diploma in Computer Science and in 1995 a PhD from the University of Kaiserslautern. After the study he worked for the Research Institute for Applied Knowledge Processing (FAW). Then he was researcher and head of the Knowledge Management research group at the German Research Center for Artificial Intelligence (DFKI). After having worked as product manager for Insiders Information Management GmbH, he joined FHNW in August 2000 as a professor for Information Systems.

Wilfrid Utz received his PhD from the University of Vienna, Research Group Knowledge Engineering in the field of metamodel design and conceptual structures. He has been involved in international research and innovation projects and gained experience in the field of modeling method conceptualization, meta-model design, and implementation of modeling tools using ADOxx in various application domains. His research and professional interest relate to the knowledge representation using meta-modeling concepts and platforms. He is responsible for managing and organising the OMILAB NPO activities.



Contact:
Prof. Dr. Knut Hinkelmann
 knut.hinkelmann@omilab.org



Contact:
Dr. Wilfrid Utz
 wilfrid.utz@omilab.org

THE TRANSFORMATION OF HILTI'S SOFTWARE SUPPORT TO CUSTOMER ADVOCATES

Dr. Marcel Müller, Hilti Entwicklungsgesellschaft mbH, Germany

ABSTRACT

Marcel Müller holds a PhD in Management of Information Systems from the University of Innsbruck. He joined Hilti in August 2022 as Head of Customer Advocates where he and his globally dispersed team are acting as the interface between customers, Hilti's market organization and the software development. Prior to this he worked for the robotics automation company KUKA in roles such as Head of Digital Product Expert, where he and his team were globally responsible for the customer success of IoT products KUKA is selling to customers; as a Program Manager for a global digital transformation program, where he was globally responsible for the transformation of internal Processes, Master Data Management and the transformation from SAP R/3 to SAP S/4 HANA; and as a Project Manager for IT Nearshoring, where he was responsible to hire over 50 employees and set up an IT Shared Service Center in Budapest (Hungary) as an extended workbench. Before working for KUKA, Marcel was part of the UniCredit Banking Group where he worked on Mergers and Acquisitions. Also, Marcel still teaches the bachelor course "IT Systems – Introduction to the Management of Information Systems" at the Department of Industrial Engineering & Management of the Management Center Innsbruck (MCI) in Austria.



Contact:
Dr. Marcel Müller
 Marcel.Mueller@hilti.com

ABSTRACT

Hilti wants to make construction better and promises its customer's that Hilti is the best partner for productivity, security and sustainability. To do so, Hilti offers not only physical products and related services but also a vast variety of software products. To live up to this customer promise for software products, it is not only important to build „Customer Centric Software Products“, but also to nurture the relationship with customers, to listen and learn from them. To fulfill this promise, Hilti established a software support organization that is currently undergoing a transformation from a „classical software support team“ to a „customer advocates team“. The focus of this transformation lies not only on the services that are offered by the customer advocates team, but more importantly it triggers a change in the traditional mindset and skill set of software support engineers. In this slot we will discuss this transformation and derive 10 things customer advocates have to be good at, based also on the Digital Design Thinking approach and workshops conducted in our OMILAB@Hilti node.

THE OPEN-SOURCE SOFTWARE: SCENE2MODEL AND CM TOOLS

Dipl.-Ing. Christian Muck, OMILAB NPO, Germany
Danial Mohammadi Amlashi, University of Vienna, Austria

ABSTRACT

Conceptual modelling without sophisticated tool support is not feasible in this day and age, as an automated processing of the modelled knowledge increases the model value for the users. OMILAB believes in the importance of open models to facilitate knowledge exchange. This conviction leads to the necessity of supporting the development of open-source software for modelling, to ease people in applying and creating modelling tools. To this end, we will show case how open-source modelling tools are used in the OMILAB Digital Innovation Environment, to support the creation and conceptualisation of innovative ideas. Therefore, the focus of this lecture is set on live presentations of modelling tools and their application.

Christian Muck works as a developer and researcher at the OMILAB NPO, where he is involved in funded research projects and creating support for OMILAB's digital innovation environment, focusing on implementing conceptual modelling tools. Additionally, he is pursuing his Ph.D. in the doctorate program Business Informatics at the University of Vienna, where his research interest lies in creating a digital modelling tool for design thinking supported by semantic-rich technologies.

Danial M. Amlashi is currently pursuing his Master's degree in Business Informatics at the University of Vienna. As a research engineer in the Knowledge Engineering research group since 2020, his interests span metamodelling, cyber-physical systems, and digital twins. In meta-modeling, he abstracts real-world entities into formal representations to optimize complex systems. He also explores the integration of physical components and computational systems in cyber-physical systems. Additionally, his work on digital twins involves creating virtual counterparts for real-time insights and decision-making.



Contact:

Christian Muck

christian.muck@omilab.org



Contact:

Danial Mohammadi Amlashi

danial.mohammadi.amlashi@univie.ac.at

THE COMMUNITY OF PRACTICE: FOCUS ON SKILLS AND CASES

Iulia Vaidian, University of Vienna, Austria
Alexander Völz, University of Vienna, Austria

ABSTRACT

Iulia Vaidian holds an MSc in Supply Chain Management from the Vienna University of Economics and Business and gained experience in design thinking, business process management and conceptual modelling concepts and technologies in her responsibilities as part of the OMILAB team. Herein she focuses on innovation using design thinking methods and their tool applications in models, as well as contributing on community management and community of practice building activities. She gained experience in various EU-funded projects, such as "OMiKA2 – Open Models Initiative" and "DigiFoF – The FoF Designer: Digital Design Skills for Factories of the Future".

Alexander Völz holds an MSc in Business Administration and has started his doctorate programme in Business Informatics at the University of Vienna in October 2021. His involvement with Business Informatics emerged during the master programme, where he was working as student assistant at the Department of Electronic Business. Early on, Alexander was involved in the publication process of scientific articles, and as a result of a fruitful collaboration project, he was able to publish a paper on the topic of Machine Learning as a Service during his master programme. Additionally to his current doctoral studies, Alexander is an employee of the research group Knowledge Engineering at the University of Vienna where he takes part in the teaching and research activities. His current research fields encompass the topics Smart City, Machine Learning as well as Metamodeling Concepts and Technologies.



Contact:

Iulia Vaidian

iulia.vaidian@univie.ac.at



Contact:

Alexander Völz

alexander.voelz@univie.ac.at

ABSTRACT

The OMILAB Community of Practice is supported at a conceptual and technical level by the underlying Digital Innovation Environment. Within this environment, conceptual modelling forms the shared domain of the community, and it is utilized to connect the business world and the digital world with physical devices through model-based approaches. The OMILAB community thereby supports the development of skills and capabilities for the next digital leaders through know-how, expertise, and resources, by answering among others: What capabilities are exercised in an experimentation and exploration environment? What skills are expected from the next digital leaders? Within this context, the domain "Smart City" forms the foundational case to demonstrate the skills required by a digital leader in today's complex environments. Namely, it is essential to have a disruptive vision while balancing the interest of multiple stakeholders from multi-disciplinary backgrounds with technological capabilities and overall feasibility.

ADOXX BEST PRACTICE: DEVELOP AND USE CONCEPTUAL MODELS WITH BEE-UP®

Dipl. Ing. Patrik Burzynski, OMILAB NPO, Germany

ABSTRACT

The research field of Conceptual Modelling identifies models as artefacts describing a real or proposed system on an abstraction level that is adequate for a given purpose. This presentation focuses on the Bee-Up multi-language modeling environment and key features that increase the value of models beyond their basic function (as diagrammatic documentation/ communication support). Bee-Up supports modeling with several established languages - BPMN, EPC, ER, UML, Petri Nets - enriched with semantic links between various model types. The goal of the presentation is to highlight that Bee-Up is not limited to diagramming with established languages, but also facilitates model-value through model analysis, transformation, execution, and integration with other systems. A selection of these will be demonstrated. Theoretical aspects about what is under the hood of Bee-Up model processing capabilities will also be briefly discussed. Bee-Up is an educational tool available at <https://bee-up.omilab.org>.

Patrik Burzynski is a computer scientist, currently working as part of the OMILAB team, developing various applications, from classical applications to cloud services. His interests include programming and meta-modelling. During his study of Business Informatics at the University of Vienna he was involved in several international research projects (e.g., plugIT, ComVantage). After finishing his master's degree (Dipl.-Ing.) he worked at the University of Vienna for the research group Knowledge Engineering as a university assistant, teaching courses on Modelling and Meta-Modelling and working on the Bee-Up tool before moving on to join the OMILAB NPO. In the OMILAB NPO he is responsible for the open-source software area and is currently working on different open-source projects, such the ADOxx meta-modelling platform.



Contact:
Dipl. Ing. Patrik Burzynski
patrik.burzynski@omilab.org

Digitalization in Smart Cities with ADOXX OMILAB@UNIVIE Team

The term Smart City describes a concept that is increasingly gaining the interest of city administrations, as more than 150 cities worldwide have formulated a strategy for becoming a Smart City. Nevertheless, a variety of definitions is used to describe different application areas within such cities and a widely accepted understanding of the concept has yet to be established. Commonly, sub-domains like Smart Mobility, Smart Environment, or Smart Governance are used to categorize present and potential Smart City applications.

In the ADOxx practice sessions, we will primarily focus on the aspects of city infrastructure and utilities. This will be a key element in realizing services such as smart parking, mobility, or the monitoring of the environment in terms of real-time alerts and safety management. In this context, three building blocks have been designed to familiarize the participants with modeling concepts, model querying and model processing in an independent application domain.

How to model concepts of a Smart City?

Basic metamodelling concepts required to realize a modelling language for a Smart City are taught. Tools of the OMILAB, e.g., the GraphRep generator will be introduced and utilized to create graphical visualizations for the Smart City concepts.

How to analyze Smart City models using query techniques?

Basic model analysis techniques will be discussed, enabling the modeller to use the information captured in the models in order to e.g., answer non-trivial questions, or support decision makers. As illustrative scenarios, queries will be executed on Smart City models to determine e.g., the healthiest running tracks or the fastest route for an emergency car in case of an accident.

How to process Smart City models using simulation?

Introduction to simulation algorithms and how they can be applied to process the knowledge codified in conceptual models. Afterwards, hands-on experience will be achieved by realizing and executing several simulation algorithms using the built-in functionality of the ADOxx platform and the Smart City models. Finally, further model processing possibilities will be showcased and discussed, e.g., stepwise car navigation in a Smart City model using AdoScript, Expressions, and event handling.



^[1] Schaffers et al. (2011): Smart Cities and the Future Internet: Towards Cooperation Frameworks for Open Innovation, in: J. Domingue et al. (Eds.): Future Internet Assembly, pp. 431–446, Springer.

^[2] Hernández-Muñoz, J.M. et al. (2011): Smart Cities at the Forefront of the Future Internet, in: J. Domingue et al. (Eds.): Future Internet Assembly, pp. 447–462, Springer.

ADOxx.org The Open Source Metamodelling Platform

Practical work during NEMO is performed using ADOxx, the meta-modelling and development platform to realize modelling tools.

ADOxx enables to:

- Create full-fledged individual modelling tools using pre-build platform features
- Develop the notation, syntax, and semantic of a modelling language with a script-based approach
- Realize Microservices encapsulating algorithms and mechanisms with the OLIVE Framework
- Deploy modelling tools: local or distributed.

Access ADOxx at: <https://www.adoxx.org/>

Domain-specific modelling tools developed on ADOxx by the OMiLAB Community of Practice available at: <https://www.omilab.org/activities/projects/>

MAKE MODELLING WORK

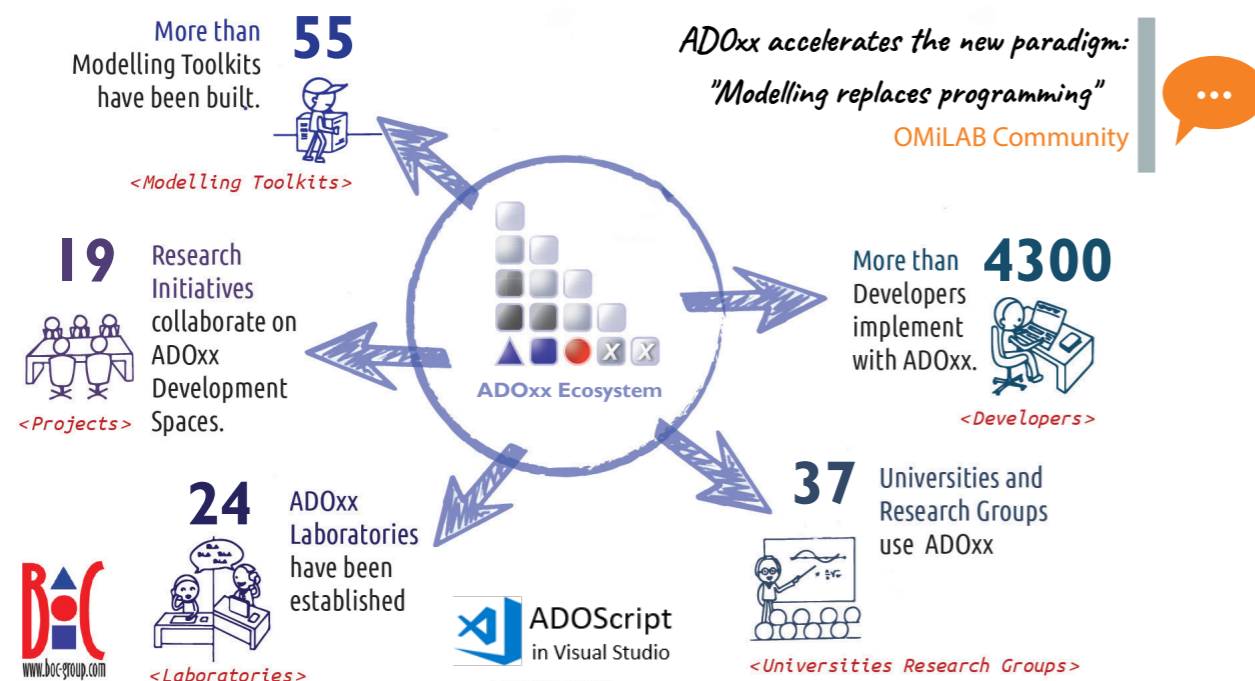

OMiLAB Community of Practice A Comprehensive Picture of the Results

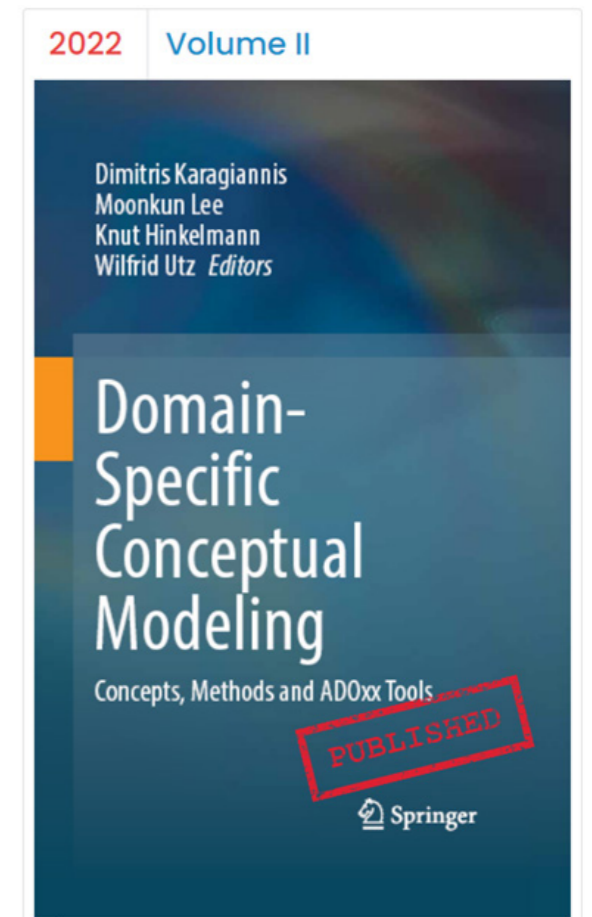
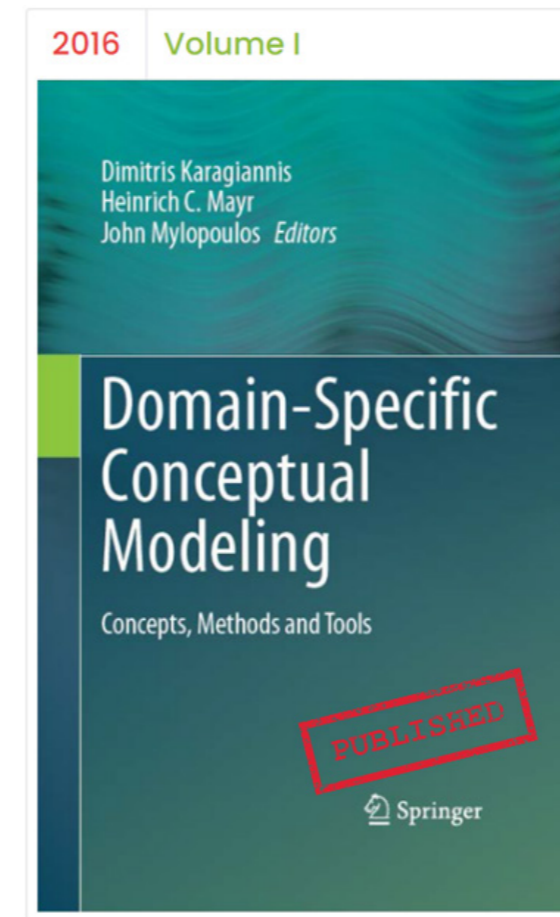

<https://books.omilab.org>

Access Volume I



Springer: <https://link.springer.com/book/10.1007/978-3-319-39417-6>

Access Volume II



Springer: <https://link.springer.com/book/10.1007/978-3-030-93547-4>

Innovate Business Models OMiLAB@UNIVIE Team

The digital era is shaped by increasingly complex business models, which are part of ecosystems, involve dependencies, integrate physical objects, and propose disruptive and innovative solutions. These business models place a strong emphasis on the interaction between humans and machines, as they require domain-specific knowledge and technical realization.

The next digital leaders should have a disruptive mindset and dare to replace existing concepts completely, as well as lead and manage their realization. The aim of this practical session is to foster co-creation in multi-disciplinary teams through design thinking using the Scene2Model tool and environment.



Engineer IoT Environments OMiLAB@UNIVIE Team

The conceptual output of the business models realized in the previous session, namely digitalized model artifacts serve as input for determining the physical and digital experiment environment.

Being aware of the semantic technologies at hand and understanding the capabilities and requirements of IoT hardware components will be the focus of this session.

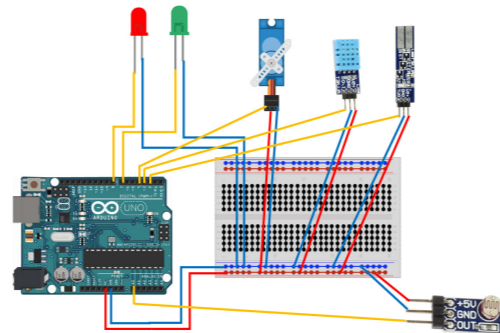

Realize CPS Applications OMiLAB@UNIVIE Team

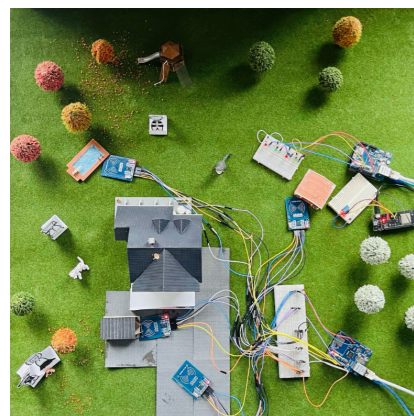

The Digital Innovation Environment of OMiLAB facilitates the realization of CPS applications, as it builds on the notion of digital business models and employs a Digital Twin as a conceptual representation of an intelligent offering.

Different sensors will be provided for participants to experiment with, instantiate a selected modelling method and realize an experiment based on the application scenario chosen.

Innovation Scenarios Using Digital Design Thinking

Innovation and transformation, as well as the emergence of disruptive business ecosystems have gained increasing significance. One approach to tackle this complex task is Design Thinking, which applies designer problem-solving techniques for agile, ideation, prototyping and testing in innovative processes through collaboration among stakeholders. The goal is to generate ideas by using different design thinking methods, based on tangible visualization of certain aspects of the problem within a developed solution space, where collaboration among stakeholders plays a central role.

Models is enabled, so that they can be processed and used within modelling tools, further decomposed, and combined with available enterprise assets. This approach enables a location and time-independent collaboration of globally distributed networks and stakeholders, implied by the digital transformation and globalization of businesses. The interplay of Conceptual Modelling and Design Thinking establishes a connection between unrestrained design artefacts and more formal abstractions (e.g., business process models).

Design Thinking enables early exploration and validation of design(s) of new services, smart products, and disruptive business models, but it restricts to location and temporal availability of stakeholders. Absent stakeholders must be informed afterward, which is often not directly supported by the Design Thinking methods applied.

Following the introduction into Design Thinking, participants will experience hands-on the storyboards as a Design Thinking method. We will use the SAP Scenes as haptic figures to depict scenes, building the key moments of a storyboard, and exploring innovative and smart solutions in the context of a „Smart City“. Supported by the Scene2Model tool, the participants will transform these scenes into diagrammatic models while simultaneously semantically enriching them.

Through the Scene2Model tool, a transformation of the physical visualization into digital conceptual mo-

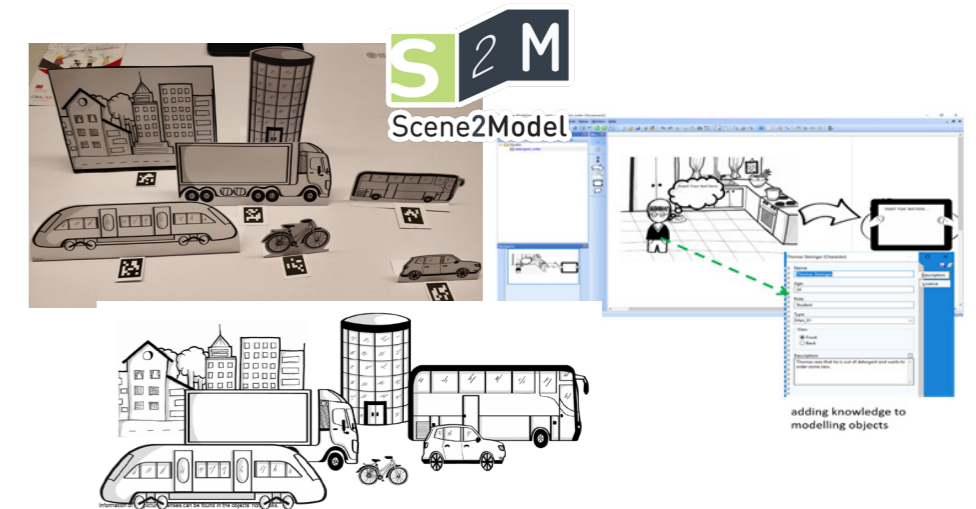

SUMMER SCHOOL

NEMO 2024

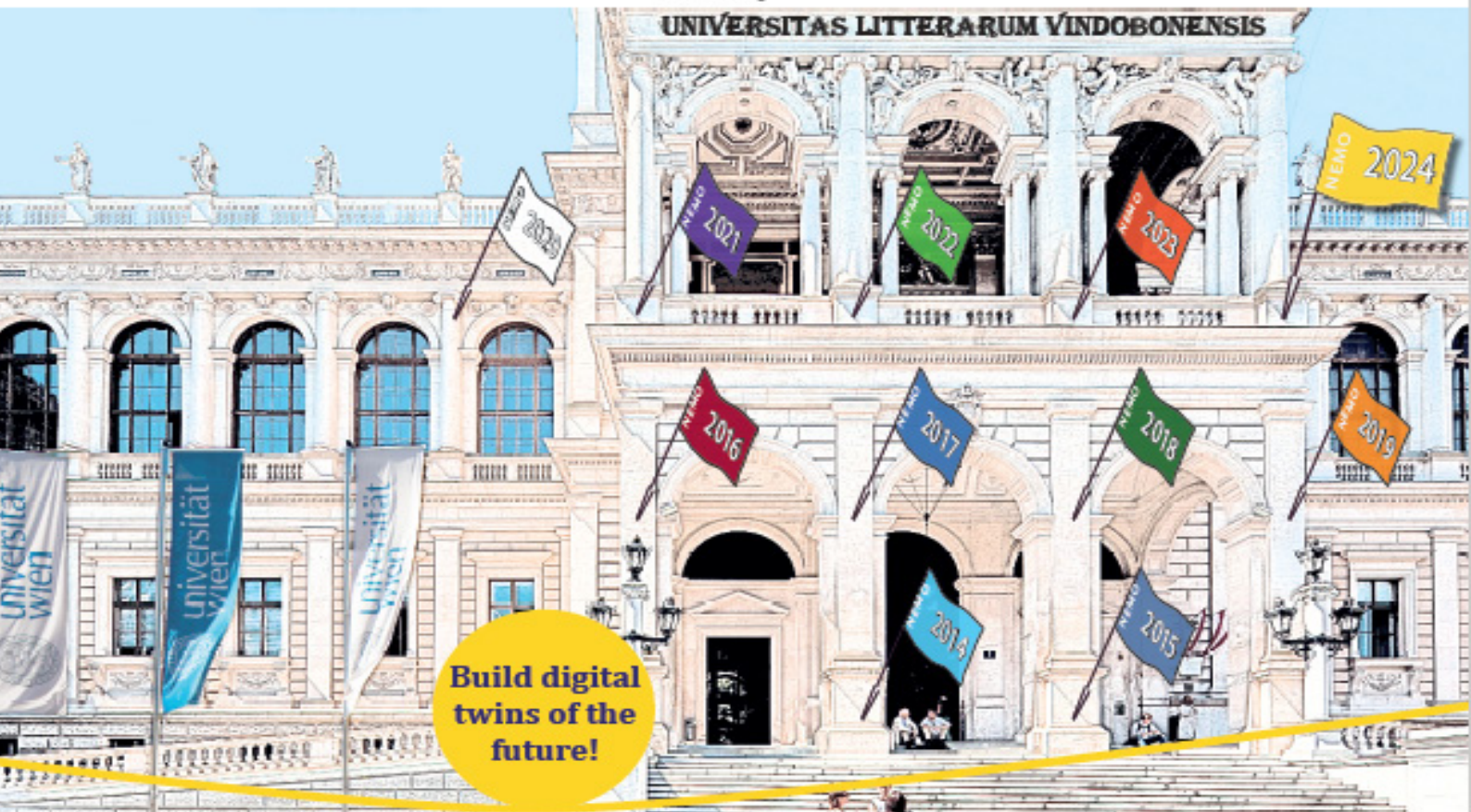

10th Edition in the NEMO Summer School Series

Become a Digital Leader!

July 15th - July 26th, 2024 - University of Vienna, Austria

<https://nemo.omilab.org>

NEMO 2024